



105 Bonnie Drive
Butler, PA 16002
724-283-4681
724-283-5939 (fax)
www.bwieagle.com

PRODUCT INFORMATION BULLETIN

OPTIMA 1 Single Channel Critical Speed Switch MODEL 10-7100 PA BOTE APPROVAL: 1155-90

DESCRIPTION

The OPTIMA 1, Model 10-7100 is one in a series of critical speed switches that monitor speed and detect motion in all types of machinery and apparatus. The 10-7100 monitors speed ranges of 60 - 800 RPMs. Models are available to meet any application requirement for underspeed, overspeed or zero speed detection. The OPTIMA 1 utilizes a non-contacting proximity sensor that may be remotely located up to two miles from the control unit. Its rugged NEMA enclosure is well suited to meet the environmental challenges of any industry. Ideal for conveyors, crushers, fans, motors and other rotating apparatus.

INSTALLATION

DISCONNECT AC Power before proceeding with instructions.

1. Mount the OPTIMA 1 control unit in a convenient location.
2. Make the following connections:
 - A. Connect power cable to 120 VAC.
 - B. Connect control cables to proper terminals in the motor control circuit.
 - C. Connect EAGLE PROX SENSOR cable to the sensor connector on the control unit.
3. Install sensor at roller. See sensor installation sheet.

SETUP AND TESTING

Final calibration should be performed with the belt loaded and running at normal speed.

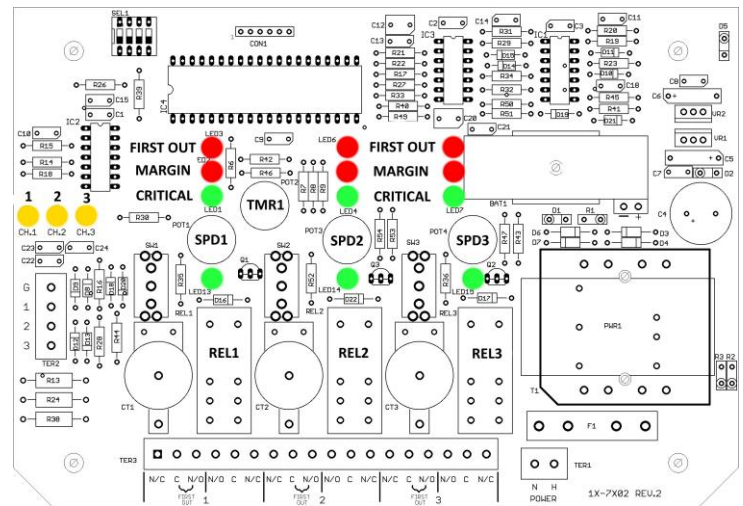
1. Turn SPEED ADJUST potentiometer (SPD1) CCW until it stops (approximately 7 o'clock).
2. Hold SW1 switch in SET* position to energize relay.
3. Turn SPEED ADJUST pot CW SLOWLY until CRITICAL SPEED LED stays on continuously.
4. Continue turning SPEED ADJUST pot CW until MARGIN LED begins to blink.**
5. After RELAY LED is illuminated, return switch to RUN position.
6. There is a "safety delay" built into all EAGLE units. This delay leaves the control relay un-energized for 2.5 seconds after critical speed has been achieved to prevent false machinery actuation during maintenance or assembly. For the Eagle 3, channel 1 is adjustable from 0 - 10 seconds using TMR1.
7. Return switch to RUN position.
8. A momentary TEST* position is provided to simulate the loss of sensor signal which releases the control relay.

* TEST position is up and SET position is down

** Using the above calibration, the control relay will drop out at a machinery slowdown of approximately 15%. For a 20% MARGIN, adjust the SPEED ADJUST control so that the MARGIN LED just comes on steady. For a 10% MARGIN, adjust the SPEED ADJUST control CCW so that the MARGIN LED has just gone out.



CONTROLS AND INDICATORS



SENSOR LEDs (CH1, CH2, CH3)	Sensor LEDs blink when targets are seen by corresponding sensor
CRITICAL LEDs	Critical speed LEDs illuminate when target speed is => setpoint. These LEDs must be on continuously for control relay to energize
MARGIN LEDs	Indicates percentage of slip (slow down) the channel is calibrated for (Off = 10%; Blinking = 15%; Solid = 20%)
FIRST OUT LEDs	Indicates that the channel shut down due to speed going below set point. If the LED is off then something external caused the belt to shut off (OPTIMA mode ONLY)
RELAY LEDs (LED13, LED14, LED15)	Illuminates when corresponding control relay is energized
SPD1, SPD2, SPD3	Speed adjust potentiometer for channels 1, 2 & 3 respectively
TMR1	Channel 1 relay on-delay potentiometer Adjustable from 0 - 10 seconds (Eagle 3 only)

Note - Not all models will have the controls & indicators shown above

OPTIMA 1

Single Channel Critical Speed Switch

MODEL 10-7100

FIRST OUT OPERATION

The EAGLE OPTIMA "First Out" capability enables the user to visually see (by an LED indicator) if the slip switch relay contacts were the first to open. Once the belt is running and the control relay in the OPTIMA unit has energized, the First-Out indication (if activated) will extinguish. If the belt begins to slip and the OPTIMA unit shuts the drive down, the First-Out LED will illuminate. This LED will stay lit until the belt is restarted and the control relay in the Optima has energized. If R1, R2, or R3 (See TYPICAL BELT STARTER) would open, this would shut the drive down and also the slip switch contacts would open. But, the First-Out LED would not be illuminated. This would allow the user to see that the slip switch relay contacts were not the first to open and cause the shutdown.

DIP SWITCH SETTINGS

Speed Setting	SW1	SW2	SW3
60-800 RPM (default)	OPEN	OPEN	Reserved for future use
6-60 RPM (ALS6) *	CLOSED	OPEN	
15-100 RPM (ALS15) *	OPEN	CLOSED	
25-200 RPM (ALS25) *	CLOSED	CLOSED	

*** Proximity Sensor Required for Proper Operation**

Eagle/Optima Settings		
	OPEN	CLOSED
SW4	Eagle Unit	Optima Unit

EAGLE/OPTIMA SETTINGS

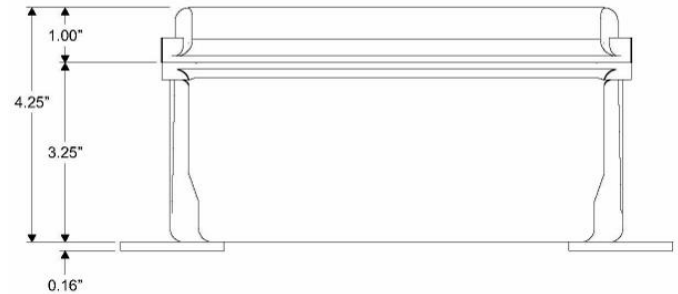
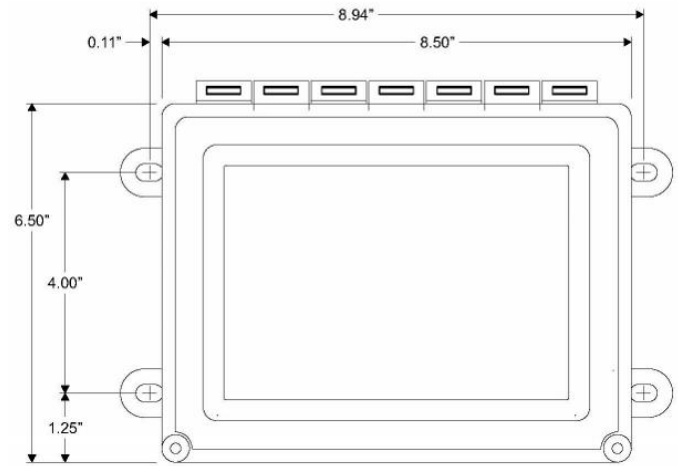
If switch 4 is open, then the unit is set to operate as a standard Eagle unit. The First Out LED will not operate in this mode. If switch 4 is closed, then the unit is set to operate as an Optima unit. In this mode the external control circuit should be wired through the set of contacts labelled "First Out" on the wiring chart. If the speed drops below the set point that was calibrated during setup, then the relay will turn off and the First Out LED will illuminate. If an external action caused the belt to shut down (i.e. pull cord, loose wire, external shutoff) then the First Out LED will be off when the relay opens.

TERMINAL STRIP WIRING

TER3					
CHANNEL 1		CHANNEL 2		CHANNEL 3	
1	N/C	7	Not Used	13	Not Used
2	C (FIRST OUT)	8	Not Used	14	Not Used
3	N/O (FIRST OUT)	9	Not Used	15	Not Used
4	N/O	10	Not Used	16	Not Used
5	C	11	Not Used	17	Not Used
6	N/C	12	Not Used	18	Not Used

TER1	
120VAC	
1	120VAC Neutral
2	120VAC Hot

DIMENSIONS



SPECIFICATIONS

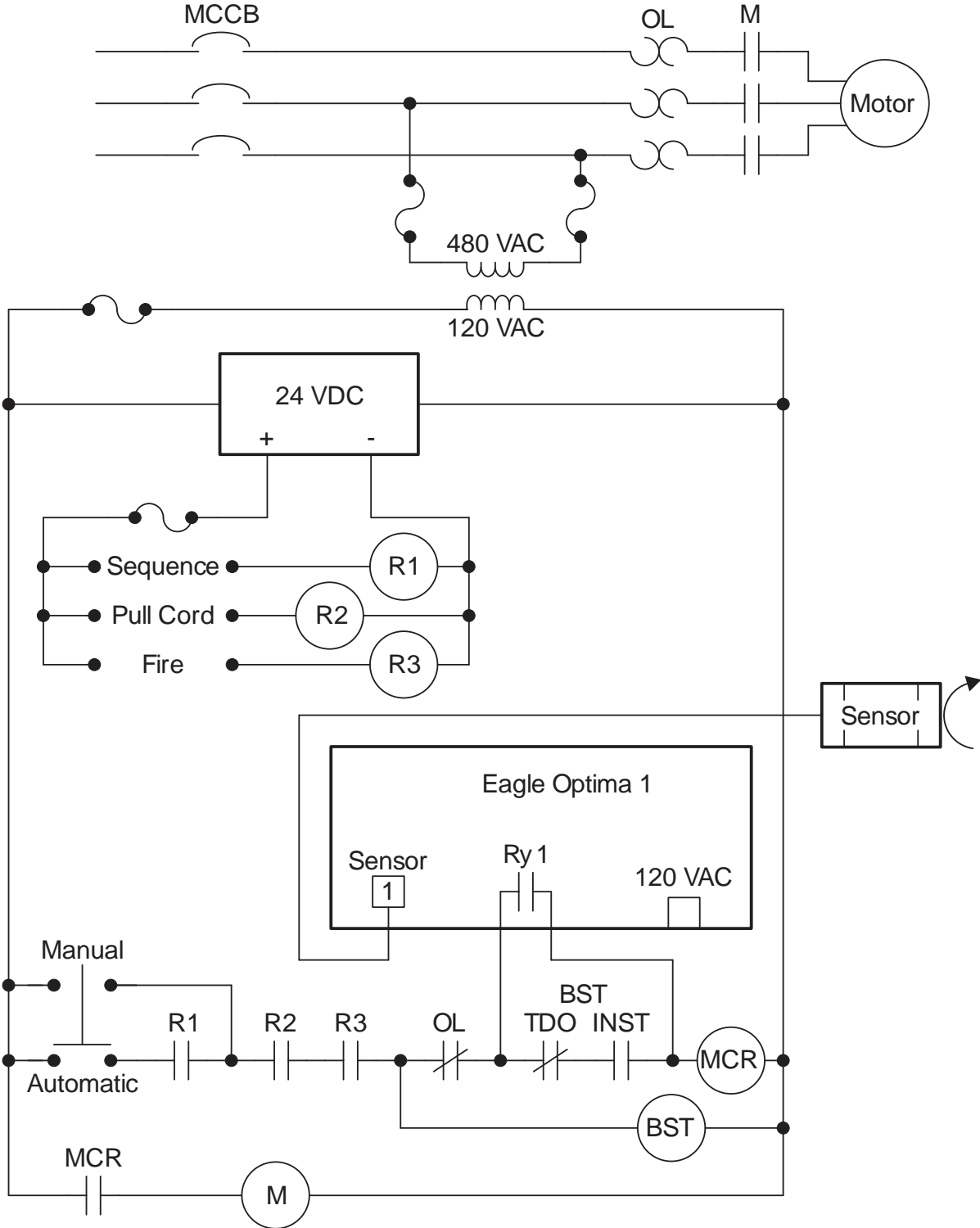
AC Input	120 VAC 15 W
Fuse Protected	1 amp
Operating Temperature	-40°C - +60°C (-40° - +140°F)
Speed Range	60 - 800 RPM
Relay Contacts	DP/DT 5 amp @ 120 VAC
First-Out AC Current Range	17mA - 5 amps
Safety Delay	2.5 Seconds
Response Time	1 Second or Less
Enclosure	Hinged fiberglass with window / NEMA 4, IP66

REPLACEMENT AND OPTIONAL PARTS

P.C. Board	10-7102
Proximity Sensor	10-7135
Relay	99-REL-0001
Strain Relief (Power Input)	99-CON-0011
Strain Relief (Control)	99-CON-0012

OPTIMA 1
Single Channel Critical Speed Switch
MODEL 10-7100

TYPICAL BELT STARTER





105 Bonnie Drive
Butler, PA 16002
724-283-4681
724-283-5939 (fax)
www.bwieagle.com

PRODUCT INFORMATION BULLETIN

PROX SENSOR Inductive Proximity Type MODELS 10-7135, 10-7136, 10-7139

DESCRIPTION

The Eagle® Proximity Sensor is designed to measure signals from any rotating apparatus and transmit this information by low-voltage 2-conductor twisted pair cable back to an Eagle control unit located up to 2 miles away. This sensor's inductive proximity technology is further enhanced with additional circuitry to reduce or eliminate the adverse effects of electrical noise. This sensor can easily be identified by its bright orange end-cap(s).

COMPATIBILITY

Eagle Proximity sensors are compatible with all Eagle Speed Switches and Dust Suppression Systems with the exception of the Eagle 2, Model 11-7000, which lacks our pulse conditioning circuitry.

THEORY OF OPERATION

The Eagle Proximity type sensor senses a target as it approaches the internal oscillator coil encapsulated in the sensor head. When the target approaches the front of the coil, this causes a decrease in the amplitude of the internal oscillator. This damping effect can be sensed at any RPM, thus the sensor can be used to sense speeds below 1 RPM and as high as several thousand RPM's.

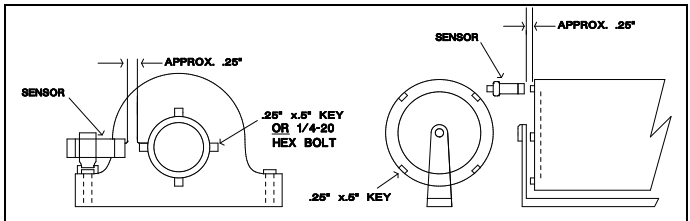
Because this type of sensor is not sensitive to the *speed* of the targets, the sensing distance remains approximately 1/8" at any speed. This eliminates "missed" targets as monitored speed changes.

INSTALLATION

1. Select the roller or shaft to be monitored. If a roller is to be monitored, be sure it is always contacting the belt.
2. Affix a target on the roller or shaft. The target should be a piece of key-stock, 1/4-20 Hex Nut, etc. (Figure 1) **NOTE:** The use of a notch or a dent is not an acceptable target for the prox sensor. This sensor must see the presence of a target, not an absence of a target as there would be with a notch or dent.
3. Mount sensor firmly with hose clamps or U-bolts to prevent it from moving or working loose. Tape is **NOT** recommended as a fastener.
4. Before tightening, check that the target passes through the center area of the sensor face. This will produce the greatest sensitivity and sensing distance. With the roller or shaft spinning, move the sensor toward the target. The LED on the sensor should blink in direct proportion to the speed of the shaft or roller. Effective distance between the sensor and target is approximately 1/8 inch.

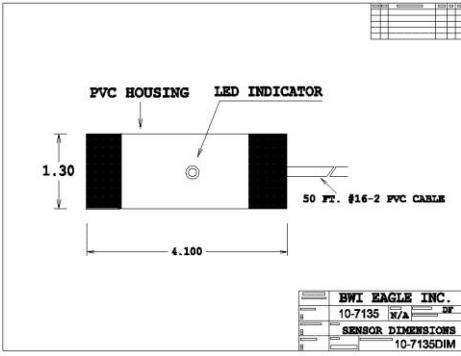


FIGURE 1



****NOTE -** Shielded cable is recommended for all above ground applications. The shield of the cable should be attached to earth ground within 2 feet of the sensor head. In severe noise environments, grounding the shield at the control module also, will eliminate any E.M.I. interference.

10-7135 SPECIFICATIONS	
Dimensions	4.12 in. x 1.32 in. O.D.
Sensor Type	Inductive Proximity (Metal)
Housing / Mounting	PVC / General Mount
Sensor Power Requirement	Current Limited 12VDC from Control
Unit Sensor Cable	Unshielded** Twisted Pair 16/2 - 50 Ft. with Connector
Distance	Sensor to Control Unit - 2 Miles
Operating Temperature Range	-40°C to 145°C / -40°F to 293°F
Minimum Sensing Speed	Less than 1 RPM

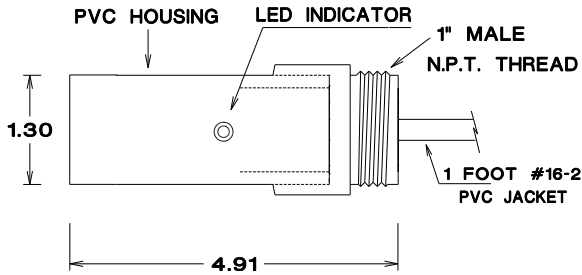


PROX SENSOR

Inductive Proximity Type

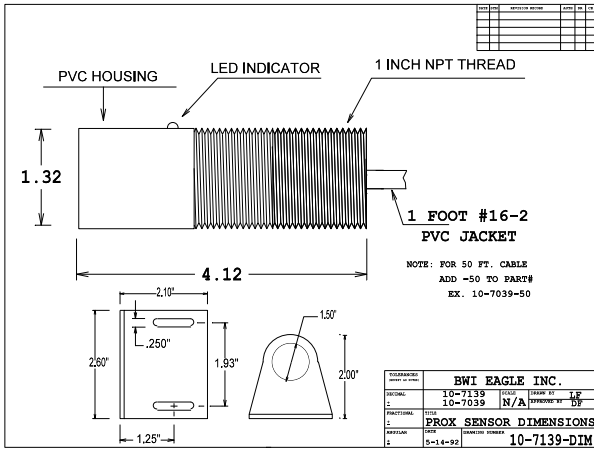
**MODELS 10-7135, 10-7136,
10-7139**

10-7136 SPECIFICATIONS



Dimensions	4.91 x 1.30 in. O.D.
Sensor Type	Inductive Proximity (Metal)
Housing / Mounting	PVC / Conduit Mount
Sensor Power Requirement	Current Limited 12VDC from Control
Unit Sensor Cable	Unshielded ** Twisted Pair 16/2 - 3 Ft. Pigtail
Distance	Sensor to Control Unit - 2 Miles
Operating Temperature Range	-40°C to 145°C / -40°F to 293°F
Minimum Sensing Speed	Less than 1 RPM

10-7139 SPECIFICATIONS



Dimensions	4.12 in. x 1.32 in. O.D.
Sensor Type	Inductive Proximity (Metal)
Housing / Mounting	Threaded PVC / Conduit or Bracket Mounting
Power Requirement	Current Limited 12VDC from Control Unit
Unit Sensor Cable	Unshielded ** Twisted Pair 16/2 - 3 Ft. Pigtail (10-7139-50 has 50' pigtail)
Distance	Sensor to Control Unit - 2 Miles
Operating Temperature Range	-40°C to 145°C / -40°F to 293°F
Minimum Sensing Speed	Less than 1 RPM

DOCUMENT DATE: 8/21/19 / PRODUCT REV. 0



105 Bonnie Drive
Butler, PA 16002
(724) 283-4681
Fax (724) 283-5939
www.bwieagle.com