

AIR-EAGLE XLT PLUS

461-40800-DC

900 MHz RF Transceiver

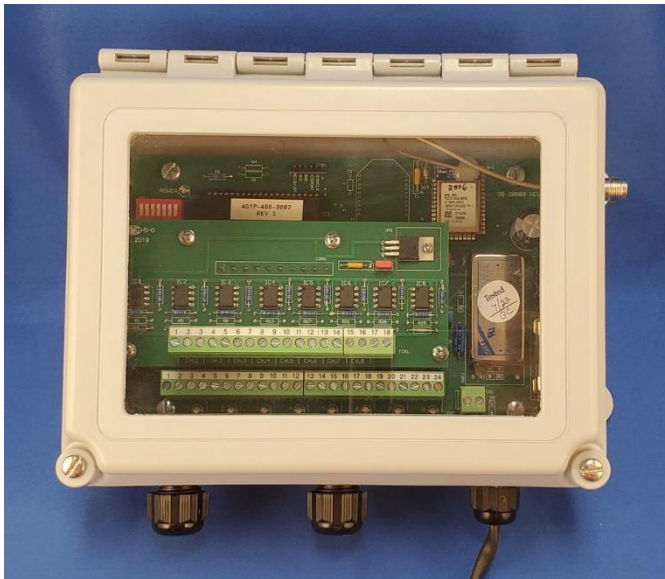

Document Date: 8/1/2023
Product Rev: 4

BWI Eagle, Inc.
105 Bonnie Dr.
Butler, PA 16002
724-283-4681
724-283-5939 (fax)
www.bwieagle.com
sales@bwieagle.com



WARRANTY STATEMENT

BWI Eagle Inc. warrants the Air-Eagle Remote Control System, if properly used and installed, will be free from defects in material and workmanship for a period of **1 year** after date of purchase. Said warranty to include the repair or replacement of defective equipment. This warranty does not cover damage due to external causes, including accident, problems with electrical power, usage not in accordance with product instructions, misuse, neglect, alteration, repair, improper installation, or improper testing. This limited warranty, and any implied warranties that may exist under state law, apply only to the original purchaser of the equipment, and last only for as long as such purchaser continues to own the equipment. This warranty replaces all other warranties, express or implied including, but not limited to, the implied warranties or merchantability and fitness for a particular purpose. BWI Eagle makes no express warranties beyond those stated here. BWI disclaims without limitation, implied warranties of merchantability and fitness for a particular purpose. Some jurisdictions do not allow the exclusion of implied warranties so this limitation may not apply to you. To obtain warranty service, contact BWI Eagle for a return material authorization. When returning equipment to BWI Eagle, the customer assumes the risk of damage or loss during shipping and is responsible for the shipping costs incurred.

SIGNAL RANGE

Max range statements are estimates based on a clear line of sight with few interferences. Actual range will vary based on transmitting power, orientation of transmitter and receiver, height of transmitting and receiving antennas, weather conditions, electronic interference, terrain, and physical obstacles, including but not limited to; walls, building structures, trees (foliage), metal objects, and landscape (hills, mountains).



WIRELESS STOP, ASTOP, and E-STOP SYSTEMS

Wireless E-STOP systems should never be considered a primary life-saving device. At least one hard-wired switch must be available in the event the wireless system is not operational. Failure to comply may result in serious injury or death to personnel and damage to equipment.



Wireless STOP and ASTOP transmitters are not failsafe emergency stop controls. They are NOT to be used as a life-saving device. They are designed for wireless control of equipment or vehicle remote operation. Failure to use as intended may result in serious injury or death to personnel and damage to equipment.



461-40800-DC



INTRODUCTION

The Air-Eagle XLT Plus is an RF system designed for extra-long range wireless remote control of electrical apparatus in a variety of industrial applications. Systems can consist of any number of receivers and handheld or contact input transmitters working together to create an extra-long range radio frequency system that operates hazardous or hard-to-reach equipment from safe, convenient locations.

Eight user selectable frequencies allow multiple systems to be used in the same area without interference.

This transceiver is equipped to send eight independent dry-contact input commands and is equipped with eight independent relays that can switch 5 amps @ 120VAC or 30VDC. The relays are user programmable for momentary or toggle/latching operation and can be directly interfaced with the customer's equipment or P.L.C. It is capable of sending and receiving remote signals from up to 5000 feet away. Longer ranges can be achieved with external antennas (See ACCESSORIES section). The Air-Eagle XLT Plus transceiver utilizes spread-spectrum technology and provides the utmost in security and reliability.

INSTALLATION

1. **DISCONNECT** power from all equipment before proceeding with installation.
2. Mount the transceiver in a convenient location.
3. Install input and output wiring to terminal strip.
4. Attach rubber duck antenna or coax from external antenna to connector on side of enclosure.
5. Connect supplied power input cable to external power source.

461-40800-DC

APPROVALS

United States (FCC)	MCQ-XBPSX
Canada (IC)	1846A-XBPSX
Australia	RCM
Brazil	ANATEL 05774-16-01209

GENERAL OPERATION

Contact closures on inputs 1 thru 8 in the control transceiver transmit to activate relays #1 thru #8 in the remote transceiver. Inputs from the remote equipment provide closures to remote transceiver that transmit to energize relays 1 thru 8 in the control transceiver.

Input Activated	Action
1	Transmits Channel 1 command to remote unit.
2	Transmits Channel 2 command to remote unit.
3	Transmits Channel 3 command to remote unit.
4	Transmits Channel 4 command to remote unit.
5	Transmits Channel 5 command to remote unit.
6	Transmits Channel 6 command to remote unit.
7	Transmits Channel 7 command to remote unit.
8	Transmits Channel 8 command to remote unit.
Input Code Received	Action
1	Relay #1 energizes, maintained momentary.
2	Relay #2 energizes, maintained momentary.
3	Relay #3 energizes, maintained momentary.
4	Relay #4 energizes, maintained momentary.
5	Relay #5 energizes, maintained momentary.
6	Relay #6 energizes, maintained momentary.
7	Relay #7 energizes, maintained momentary.
8	Relay #8 energizes, maintained momentary.

461-40800-DC

TERMINAL STRIP WIRING

Relay Outputs					
Terminal 1	N/O Relay #1	Terminal 10	N/O Relay #4	Terminal 19	N/O Relay #7
Terminal 2	C Relay #1	Terminal 11	C Relay #4	Terminal 20	C Relay #7
Terminal 3	N/C Relay #1	Terminal 12	N/C Relay #4	Terminal 21	N/C Relay #7
Terminal 4	N/O Relay #2	Terminal 13	N/O Relay #5	Terminal 22	N/O Relay #8
Terminal 5	C Relay #2	Terminal 14	C Relay #5	Terminal 23	C Relay #8
Terminal 6	N/C Relay #2	Terminal 15	N/C Relay #5	Terminal 24	N/C Relay #8
Terminal 7	N/O Relay #3	Terminal 16	N/O Relay #6		
Terminal 8	C Relay #3	Terminal 17	C Relay #6		
Terminal 9	N/C Relay #3	Terminal 18	N/C Relay #6		
Contact Inputs					
Terminal 1	Common Input 1	Terminal 7	Common Input 4	Terminal 13	Common Input 7
Terminal 2	Input 1	Terminal 8	Input 4	Terminal 14	Input 7
Terminal 3	Common Input 2	Terminal 9	Common Input 5	Terminal 15	Common Input 8
Terminal 4	Input 2	Terminal 10	Input 5	Terminal 16	Input 8
Terminal 5	Common Input 3	Terminal 11	Common Input 6	Terminal 17	Not Used
Terminal 6	Input 3	Terminal 12	Input 6	Terminal 18	Not Used
AC Power Inputs					
Terminal 1	100-250VAC	Terminal 2	100-250VAC		

461-40800-DC

RELAY & FREQUENCY SETUP

The unit is shipped from the factory with SEL1 switches in the open positions. All eight relays will operate as maintained momentary and unit is receiving commands on frequency one. To change default settings, follow the instructions below:

1. ***IMPORTANT***
Disconnect power from unit.
2. Remove top cover.
3. Select desired relay operation and/or frequency using the table.
4. Reattach cover.
5. Reconnect power to unit.
6. Programming is complete.

RELAY CONFIGURATION			
SEL1 SW#	OPEN (default)	CLOSED	
SW1	Relays #1 - #8 maintained momentary	Relays #1 - #8 toggle latch	
<p>Maintained Momentary – Relay mimics button or input – when pressed or closed, relay will be energized; when released, relay de-energizes.</p> <p>Toggle Latch – Relay changes and holds its state each time the corresponding button or input is pressed or closed.</p>			
SYSTEM CONFIGURATION			
SEL1 SW#	OPEN (default)	CLOSED	
SW3	Main Unit	Secondary Unit	
<p>Important! When using more than one transceiver, they will function better if one is set to Main and the other to Secondary.</p>			
REPEATER CONFIGURATION			
SEL1 SW#	OPEN (default)	CLOSED	
SW4	Repeater Mode OFF	Repeater Mode ON	
FREQUENCY SETUP			
NETWORK FREQUENCY	SW5	SW6	SW7
1 (default)	OPEN	OPEN	OPEN
2	CLOSED	OPEN	OPEN
3	OPEN	CLOSED	OPEN
4	CLOSED	CLOSED	OPEN
5	OPEN	OPEN	CLOSED
6	CLOSED	OPEN	CLOSED
7	OPEN	CLOSED	CLOSED
8	CLOSED	CLOSED	CLOSED
Note – SW2 & SW9 not used on this model			

461-40800-DC

SPECIFICATIONS

Power Supply	9-36 VDC, 10W
Relay Contacts	SPDT 5 amp @ 120VAC or 30VDC per channel
Fuse Protected	2 amp
Frequency	900 MHz Spread Spectrum
Transmitter Data	Eight Dry Contact Inputs
Transceiver Range	Up to 1 mile with Rubber Duck antenna. Up to 10 miles with external antenna. *
RF Networks	Eight Independent Network Frequencies
RF Output Power	1W
Operating Temperature	-40° F to +185° F
Enclosure	Hinged fiberglass with window (NEMA 3, 3R, 4, 12, 13)
<p>*Note: Max range statements are estimates based on a clear line of sight with few interferences. Actual range will vary based on transmitting power, orientation of transmitter and receiver, height of transmitting and receiving antennas, weather conditions, electronic interference, terrain, and physical obstacles, including but not limited to; walls, building structures, trees (foliage), metal objects, and landscape (hills, mountains).</p>	

ACCESSORIES

STANDARD ANTENNA (INCLUDED)	
900MHz TNC Portable "Rubber Duck" Antenna	49-1103
MOBILE/BASE ANTENNAS (OPTIONAL) Used to help achieve max range in non-line-of-sight and line-of-sight applications. Contact BWI Eagle for recommendations.	
900MHz Thru-Hole/Bracket Mount Mobile Antenna	49-2101
900MHz Magnet Mount Mobile Antenna	49-2102
900MHz Omni Directional Base Antenna	49-3101
900MHz Yagi Directional Base Antenna	49-3102
HIGH QUALITY COAX CABLE Used to connect external antennas to control unit.	
Flex Coax Cable w/Connectors (Available in 5', 15', 25', 30', 40', 60', 80', and 100' lengths)	49-4000-XX (XX = length in feet)
BULKHEAD EXTENSION Used to provide an external antenna connection when mounting control unit inside another enclosure.	
TNC Male to TNC Bulkhead Cable Assembly (Available in 2', 4', and 7' lengths)	49-5004-X-ISO (X = length in feet)

461-40800-DC

DIMENSIONS

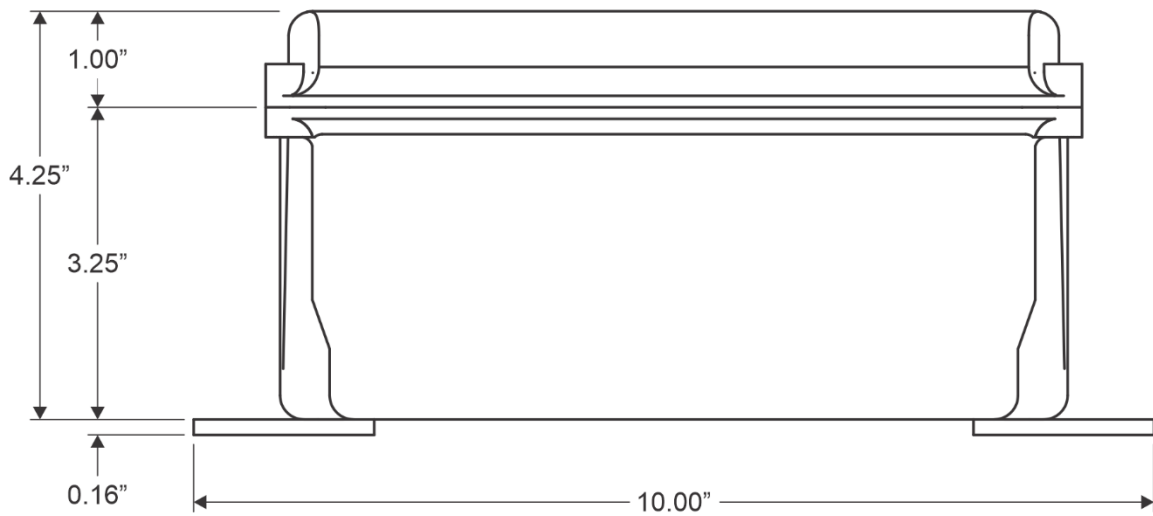
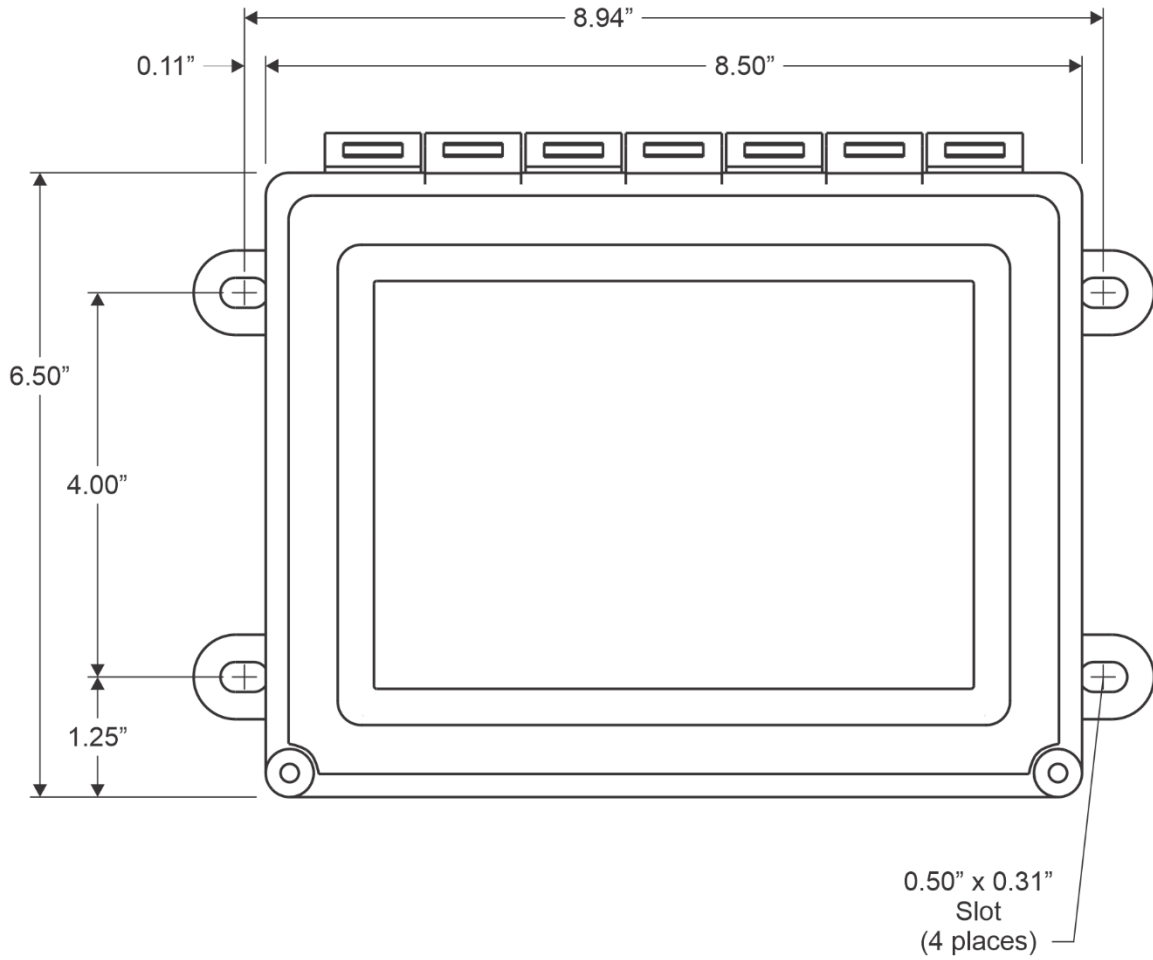



105 Bonnie Drive
Butler, PA 16002
724-283-4681
724-283-5939 (fax)
www.bwieagle.com

DRY CONTACT INPUT WIRING 8-Input Transmitter

Standard wiring of a dry contact input transmitter

Shorting together the contacts of the respective channel will cause it to transmit. This can be done with any type of manual or automatic switch.

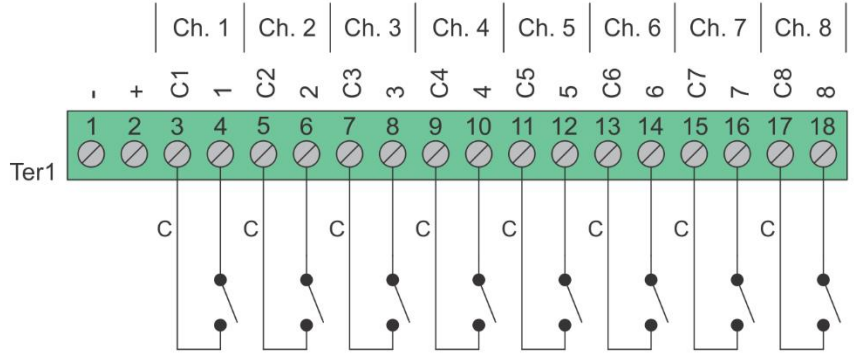

Standard Wiring for Common Ground Applications

Because each channel shares a common (C) terminal, inputs can be wired as shown to allow for fewer conductors to be run to the transmitter.

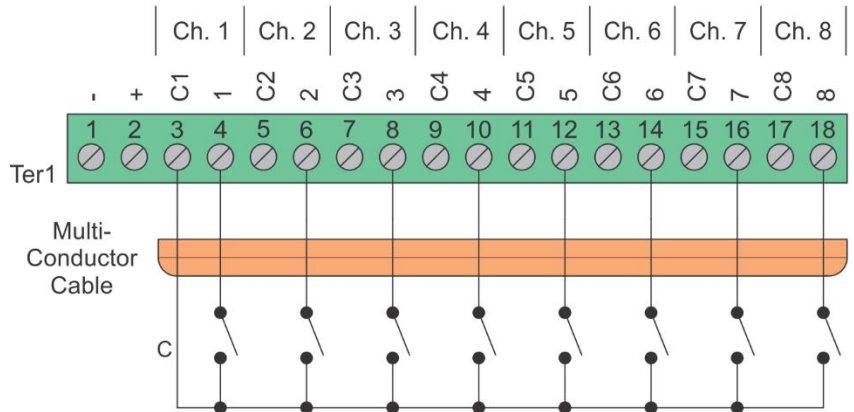

SPDT Switches

The common (C) terminal of the switch only needs to be connected to one of the channels ground terminal. In this configuration four channels would be transmitting all the time. A switch with a center "off" position would allow transmitting to stop. In this example channels 2, 4, 6, and 8 are transmitting.

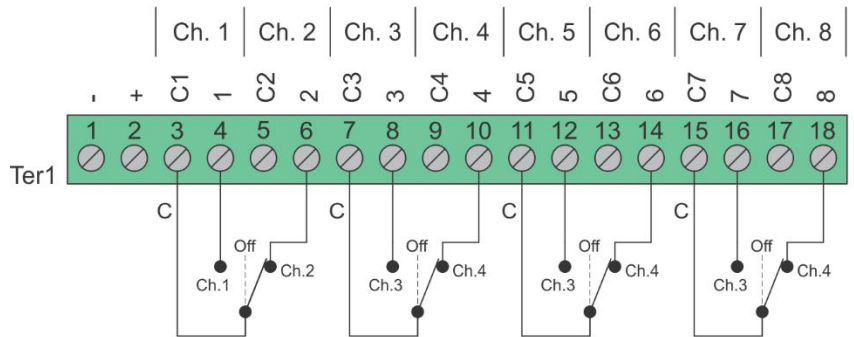

Wiring configurations shown here are examples. The wiring for your application may differ. Call BWI Eagle for assistance or consult an electrician.



105 Bonnie Drive
Butler, PA 16002
724-283-4681
724-283-5939 (fax)
www.bwieagle.com

RELAY OUTPUT WIRING 8-Relay Receiver

Receiver outputs are dry relay contacts, like an SPDT switch. When the relay is in a de-energized state, the N/C (normally closed) contact is connected to C (common). When the relay is energized the N/O (normally open) contact is connected to C (common).

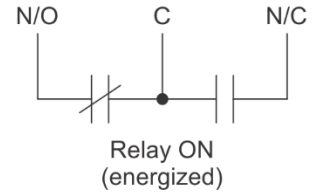
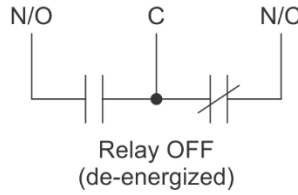

Normally Open Application with Externally Supplied Voltage

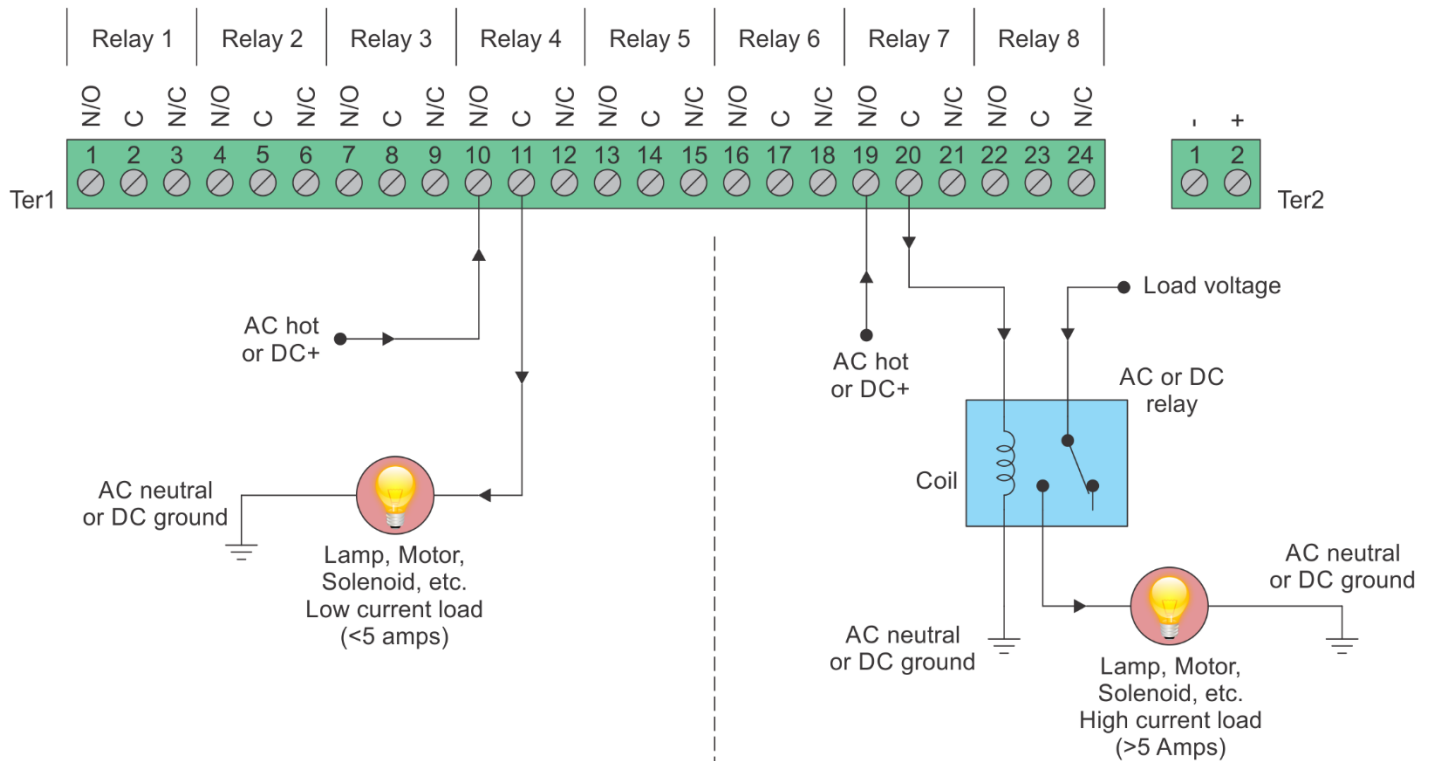

Internal Relay - Loads Less Than 5 Amps

Loads up to 5 Amps may be wired directly to the internal relays. Wiring to the N/O contact will cause the load to turn on when the relay is energized (the load is on when the relay is on). Wiring to the N/C contact will cause the load to turn on when the relay is de-energized (the load is on when the relay is off). AC or DC voltages can be switched through the relay.

External Relay - Loads Over 5 Amps

Loads over 5 Amps must use an external high current relay. Diagram shows how to turn on the relay using the lower current internal relay of the receiver. AC or DC voltages can be switched through the relay. Note: A protection diode for DC coils or an MOV for AC coils is recommended to reduce inductive EMI noise.

Wiring configurations shown here are examples. The wiring for your application may differ.
Call BWI Eagle for assistance or consult an electrician.