



238 Pillow Street  
Butler, PA 16001  
724-283-4681  
724-283-5939 (fax)  
www.bwieagle.com

# PRODUCT INFORMATION BULLETIN

## OPTIMA 1 Single Channel Critical Speed Switch MODEL 10-7100N4W-3600

### DESCRIPTION

The model 10-7100N4W-3600 is one in a series of critical speed switches that monitor speed and detect motion in all types of machinery and apparatus. The 10-7000N4W-3600 monitors speed ranges of 220 - 3600 RPMs. Models are available to meet any application requirement for underspeed, overspeed or zero speed detection. The OPTIMA 1 utilizes a non-contacting proximity sensor that may be remotely located up to two miles from the control unit. Its rugged NEMA 4 enclosure, with display window, is well-suited to meet the environmental challenges of any industry. Ideal for conveyors, crushers, fans, motors and other rotating apparatus.

### INSTALLATION

Disconnect AC power before proceeding with installation

- Make the following connections:
  - Connect power cable to 120 VAC.
  - Connect control cable to appropriate terminal in the motor control circuit. (See TYPICAL BELT STARTER)
  - Connect the EAGLE PROX SENSOR to the connector on the OPTIMA control unit.
- Install sensor at roller or shaft. See sensor installation sheet.

### SETUP AND TESTING

Final calibration should be performed with the belt loaded and running at normal speed.

- Turn SPEED control (R13) CCW until it stops. (Approximately 7 o'clock)
- Hold TEST/SET switch in the SET position to energize relay (RY1).
- Turn SPEED control CW SLOWLY, until CRITICAL LED (LED 53) stays on continuously.
- Continue turning SPEED control until MARGIN LED (LED 3) begins to blink.\*\*
- After the RELAY STATUS LED (LED 7) is illuminated, return the TEST/SET switch to the RUN (center) position.
- A momentary TEST position is provided to simulate the loss of sensor signal which releases the control relay.

\*\*\* Using the above calibration, the control relay will drop out at a machinery slow down of approximately 15%. For a 20% margin, adjust the SPEED control so that the MARGIN LED just comes on steady. For a 10% margin, adjust the SPEED control CCW so that the MARGIN LED has just gone out. If a margin greater than 20% is desired, consult BWI Eagle, Inc. For ALL speed adjustments, the CRITICAL SPEED LED must stay on continuously.

### CONTROLS AND INDICATORS

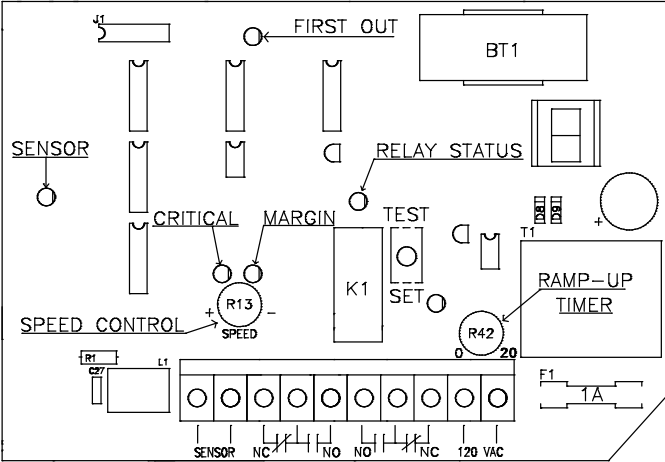

**CRITICAL SPEED LED** - Must be illuminated continuously to allow control relay to energize.

**MARGIN LED** - Indicates the percentage of slip the user has calibrated the unit for: (Out = 10%, Blinking = 15%, Solid = 20%)

**FIRST-OUT LED** - When illuminated, indicates that the OPTIMA unit has caused the shutdown.

**SENSOR LED** - Pulses at the rate of speed being received by the sensor.

**TEST SWITCH** - When pushed, simulates a loss of sensor signal which will drop out the control relay.

### TERMINAL STRIP WIRING

The OPTIMA unit is shipped with the control cables installed on the normally open contacts. The control cables should be installed directly in the series circuit driving the motor control relay. (See TYPICAL BELT STARTER) The additional contacts supplied on the printed circuit card can be used, but the First-Out capability is only installed on the one set of normally open contacts per channel.

CHANNEL 1		120 VAC	
1	Sensor (+)	9	120 VAC
2	Sensor (-)	10	120VAC
3	N/C		
4	Common (1 <sup>st</sup> OUT)		
5	N/O (1 <sup>st</sup> OUT)		
6	N/O		
7	Common		
8	N/C		

# OPTIMA 1

Single Channel Critical Speed Switch

**MODEL 10-7100N4W-3600**

## FIRST OUT OPERATION

The EAGLE OPTIMA "First Out" capability enables the user to visually see (by an LED indicator) if the slip switch relay contacts were the first to open. Once the belt is running and the control relay in the OPTIMA unit has energized, the First-Out indication (if activated) will extinguish. If the belt begins to slip and the OPTIMA unit shuts the drive down, the First-Out LED will illuminate. This LED will stay lit until the belt is restarted and the control relay in the Optima has energized. If R1, R2, or R3 (See TYPICAL BELT STARTER) would open, this would shut the drive down and also the slip switch contacts would open. But, the First-Out LED would not be illuminated. This would allow the user to see that the slip switch relay contacts were not the first to open and cause the shutdown.

## SPECIFICATIONS

AC Input	120VAC 50/60hz @ 10W
Fuse Protected	1 amp
Speed Range	220 - 3600 RPM
Relay Contacts	DPDT 5 amp @ 120VAC
First-Out Current Range	17mA - 8 amps
Response Time	1 Second or Less
Enclosure	NEMA 4X w/Window

## DIMENSIONS

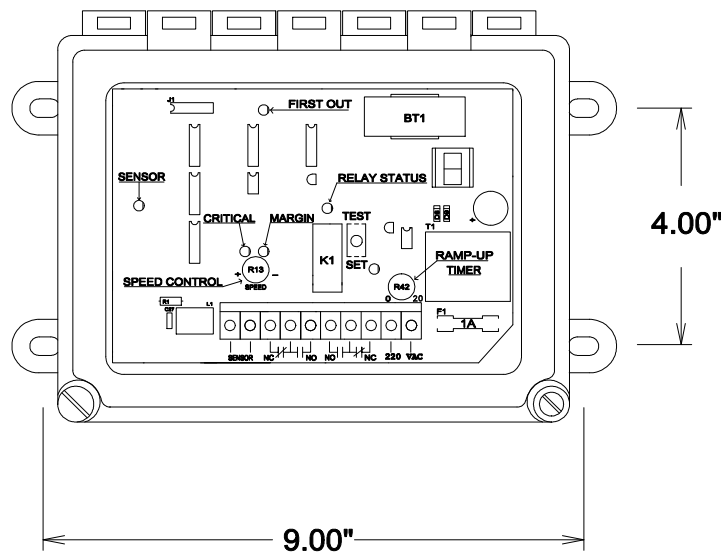

## REPLACEMENT PARTS

DESCRIPTION	PART NO.
P.C. Board	10-7102-3600
Proximity Sensor - General Mount	10-7135
Proximity Sensor - Conduit Mount	10-7136
Proximity Sensor - Threaded w/Bracket	10-7139
Relay	99-REL-0001
Strain Relief (Power Input)	99-CON-0011
Strain Relief (Control)	99-CON-0012

## OPTIONAL SENSOR ORDERING INFO

Unit Ships Standard with Model 10-7135 Prox Sensor, General Mount, Integral 50' Cable See Below For Other Sensors Available:	
If you prefer unit with:	Order As:
Proximity Sensor, Threaded PVC w/Mounting Bracket & 3' Pigtail, 50' Cable Extension Provided	10-7100N4W-3600-7139
Proximity Sensor, Conduit Mount w/3' Pigtail, 50' Cable Extension Provided	10-7100N4W-3600-7136

## TYPICAL BELT STARTER

TYPICAL BELT STARTER  
EAGLE OPTIMA 1 INSTALLATION

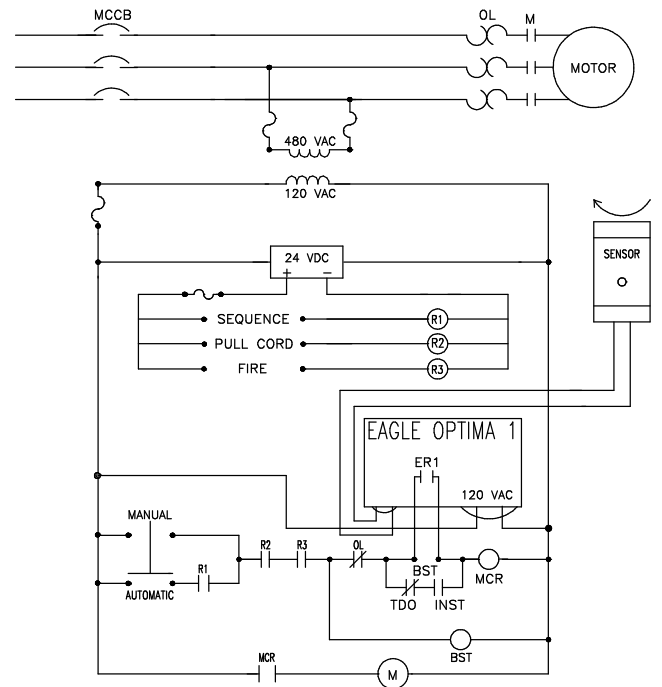

FIGURE 1

DOCUMENT DATE: 14-Oct-05



238 Pillow Street  
Butler, PA 16001  
(724) 283-4681  
Fax (724) 283-5939  
[www.bwieagle.com](http://www.bwieagle.com)

