



238 Pillow Street  
Butler, PA 16001  
724-283-4681  
724-283-5939 (fax)  
www.bwieagle.com

# PRODUCT INFORMATION BULLETIN

## I.S. OPTIMA 1 Intrinsically Safe, Single Channel Critical Speed Switch **MODEL 10-9100N4WALS**

### DESCRIPTION

The 10-9100N4WALS models are a series of intrinsically safe critical speed switches that monitor speed and detect motion in all types of machinery and apparatus. Complete with built-in Zener Barrier, The 10-9100 monitors speed ranges of 6 - 200 RPMs. Models are available to meet any application requirement for underspeed, overspeed or zero speed detection. The I.S. OPTIMA 1 utilizes a non-contacting intrinsically safe proximity sensor that may be remotely located up to one mile from the control unit. Its rugged NEMA enclosure, with up-front display, is well-suited to meet the environmental challenges of any industry. Ideal for conveyors, crushers, fans, motors and other rotating apparatus.

### INSTALLATION

- Disconnect AC power before proceeding with installation
1. Mount the I.S. OPTIMA 1 control unit in a certified XP enclosure or fresh air.
  2. Make the following connections:
    - A. Connect power cable to 120 VAC.
    - B. Connect control cable to appropriate terminal in the motor control circuit. (See TYPICAL BELT STARTER)
    - C. Connect the EAGLE I.S. PROX SENSOR to the connector on the control unit.
  3. Install sensor at roller or shaft. See sensor installation sheet.

### SETUP AND TESTING

Final calibration should be performed with the belt loaded and running at normal speed.

1. Turn SPEED control (R13) CCW until it stops. (approximately 7 o'clock).
2. Hold switch (S1) in SET position to energize relay.
3. Turn SPEED control CW SLOWLY until CRITICAL SPEED LED (LED 5) stays on continuously.
4. Continue turning SPEED control CW until MARGIN LED (LED 3) stays on continuously.
5. Turn SPEED control CCW until MARGIN LED begins to blink at the same rate as the SENSOR LED.
6. After RELAY STATUS LED (LED 7) is illuminated, return switch (S1) to the RUN position (center).
7. A momentary TEST position is provided to simulate the loss of sensor signal which releases the control relay.

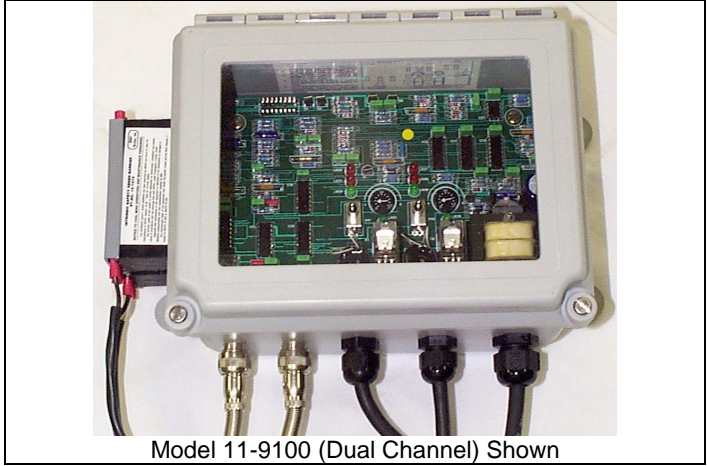

Model 11-9100 (Dual Channel) Shown

### CONTROLS AND INDICATORS

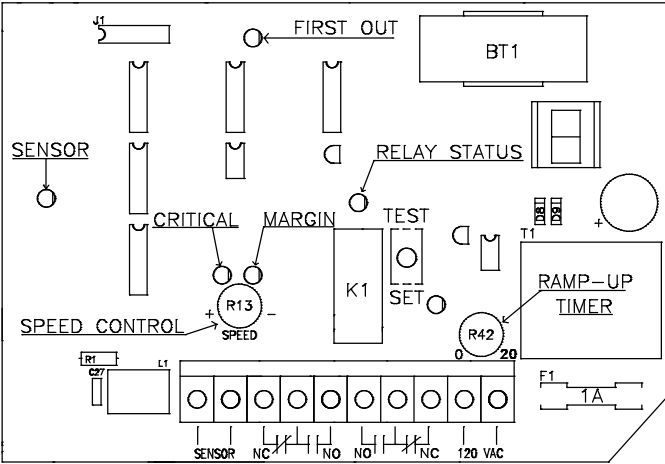

### TERMINAL STRIP WIRING

The OPTIMA unit is shipped with the control cables installed on the normally open contacts. The control cables should be installed directly in the series circuit driving the motor control relay. (See TYPICAL BELT STARTER) The additional contacts supplied on the printed circuit card can be used, but the First-Out capability is only installed on the one set of normally open contacts per channel.

CHANNEL 1		120 VAC	
1	Sensor (+)	9	120 VAC
2	Sensor (-)	10	120VAC
3	N/C		
4	Common (1 <sup>ST</sup> OUT)		
5	N/O (1 <sup>ST</sup> OUT)		
6	N/O		
7	Common		
8	N/C		

# I.S. OPTIMA 1

Intrinsically Safe, Single Channel Critical Speed Switch

**MODEL 10-9100N4WALS**

## FIRST OUT OPERATION

The EAGLE OPTIMA "First Out" capability enables the user to visually see (by an LED indicator) if the slip switch relay contacts were the first to open. Once the belt is running and the control relay in the OPTIMA unit has energized, the First-Out indication (if activated) will extinguish. If the belt begins to slip and the OPTIMA unit shuts the drive down, the First-Out LED will illuminate. This LED will stay lit until the belt is restarted and the control relay in the Optima has energized. If R1, R2, or R3 (See TYPICAL BELT STARTER) would open, this would shut the drive down and also the slip switch contacts would open. But, the First-Out LED would not be illuminated. This would allow the user to see that the slip switch relay contacts were not the first to open and cause the shutdown.

## DIMENSIONS

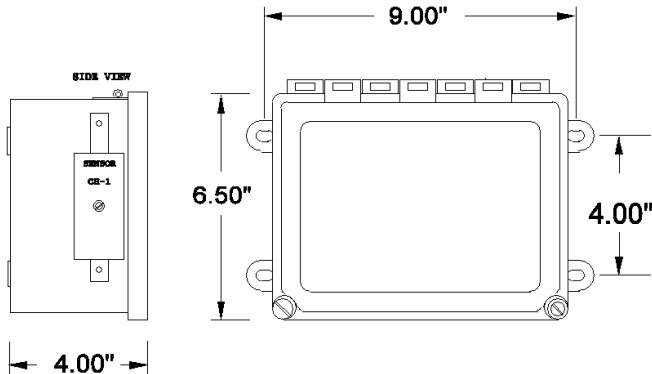

## INDICATORS

**CRITICAL SPEED LED** - Must be illuminated continuously to allow control relay to energize.

**MARGIN LED** - Indicates the percentage of slip the user has calibrated the unit for: (Out = 10%, Blinking = 15%, Solid = 20%)

**FIRST-OUT LED** - When illuminated, indicates that the OPTIMA unit has caused the shutdown.

**SENSOR LED** - Pulses at the rate of speed being received by the sensor.

**TEST SWITCH** - When pushed, simulates a loss of sensor signal which will drop out the control relay.

## SPECIFICATIONS

AC Input	120 VAC 15 W
Fuse Protected	1 amp
Speed Range: ALS-6	6 - 60 RPM
ALS-15	15 - 100 RPM
ALS-25	25 - 200 RPM
Relay Contacts	DPDT 8 amp @ 120 VAC
First-Out Current Range	17mA - 8 amps
Response Time	1 Second or Less
Enclosure	NEMA 12 Windowed

## REPLACEMENT AND OPTIONAL PARTS

DESCRIPTION	PART NO.
P.C. Board	10-9102ALS6, 15 or 25
I.S. Threaded PVC Proximity Sensor	10-7039
I.S. Zener Barrier	10-7072
Relay	99-REL-0001
Strain Relief (Power Input)	99-CON-0011
Strain Relief (Control)	99-CON-0012

## TYPICAL BELT STARTER

TYPICAL BELT STARTER  
EAGLE OPTIMA 1 INSTALLATION

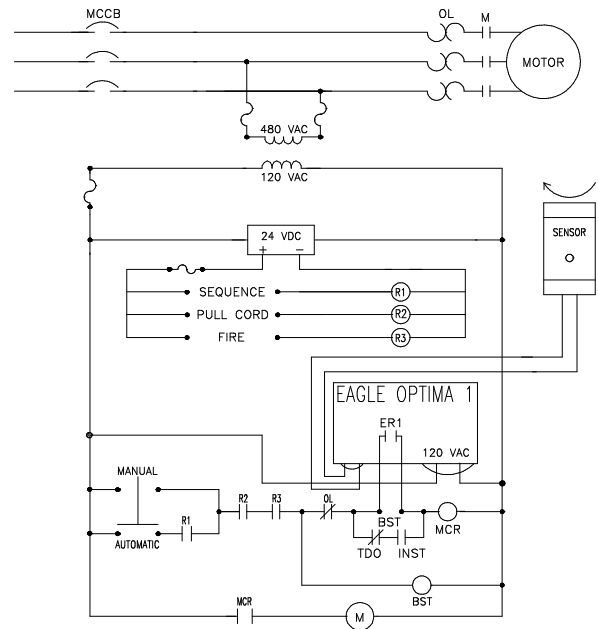

FIGURE 1

DOCUMENT DATE: 11-Aug-04



238 Pillow Street  
Butler, PA 16001  
(724) 283-4681  
Fax (724) 283-5939  
[www.bwieagle.com](http://www.bwieagle.com)

