



105 Bonnie Drive
Butler, PA 16002
724-283-4681
724-283-5939 (fax)
www.bwieagle.com

PRODUCT INFORMATION BULLETIN

TAC-SWITCH Critical Speed Switch MODEL 22-8800-2000

BOTE APPROVAL

1207-90

DESCRIPTION

The model 22-8800-2000 TAC-SWITCH is one in a series of critical speed switches that monitor speed and detect motion in all types of machinery and apparatus. Complete with ramp-up timer, the 22-8800-2000 monitors speed ranges of 200 - 2000 RPMs. The TAC-SWITCH utilizes a non-contacting proximity sensor that may be remotely located up to two miles from the control unit. Enclosed in durable ABS plastic, the socket mounted control unit conveniently mounts inside an existing electrical panel or O.E.M. control box. Ideal for conveyors, crushers, fans, motors and other rotating apparatus.

INSTALLATION

Disconnect AC power before proceeding with installation

1. Mount the TAC-SWITCH socket inside an existing control panel or other suitable protective enclosure
2. Make the following connections on the socket:

TERMINAL	CONNECTION
1	Sensor - Common (-)
2	Sensor - Positive (+)
3	No Connection
4	Earth Ground
5 - 6	120 VAC
7	Relay - N/C (1)
8	Relay - Common (1)
9	Relay - N/O (1)
10	Relay - N/C (2)
11	Relay - Common (2)
12	Relay - N/O (2)

3. Install EAGLE PROXIMITY SENSOR at roller or shaft. See sensor installation section.

Note: When 120VAC is applied to the unit, the timer function will energize the control relay. After the time has elapsed, the relay will de-energize unless the belt is running at the set speed. To reset the timer, the 120VAC must be removed.



Model 22-8800 Shown

CONTROLS AND INDICATORS

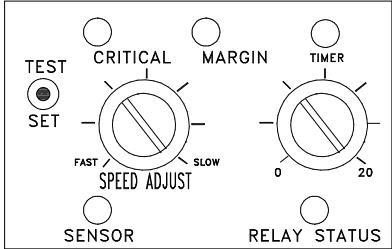

SET UP AND TESTING

Final calibration should be performed with the belt loaded and running at normal speed.

1. Turn SPEED control CCW until it stops (approximately 7 o'clock)
2. Hold switch in set position to energize relay.
3. Turn SPEED control CW slowly until CRITICAL SPEED LED stays on continuously.
4. Continue turning SPEED control until MARGIN LED begins to blink***
5. After RELAY STATUS LED is illuminated, return switch to RUN position (center)
6. A momentary TEST position is provided to simulate the loss of sensor signal which releases the control relay
7. Set timer for desired ramp-up period

*** Using the above calibration, the control relay will drop out at a machinery slow down of approximately 15% For a 20% margin, adjust the SPEED control so that the MARGIN LED just comes on steady. For a 10% margin, adjust the SPEED control CCW so that the MARGIN LED has just gone out. If a margin greater than 20% is desired, consult BWI Eagle, Inc. For ALL speed adjustments, the CRITICAL SPEED LED must stay on continuously.

TAC-SWITCH

Critical Speed Switch

MODEL 22-8800-2000

SPECIFICATIONS

AC Input	120VAC 10W
Fuse Protected	1 amp
Speed Range	200 - 2000 RPM
Relay Contacts	DPDT 5 amp @ 120VAC
Safety Delay	1 Second
Response Time	1 Second or Less
Start-up Timer	1 - 20 Seconds, Adjustable
Enclosure	ABS Plastic

DIMENSIONS

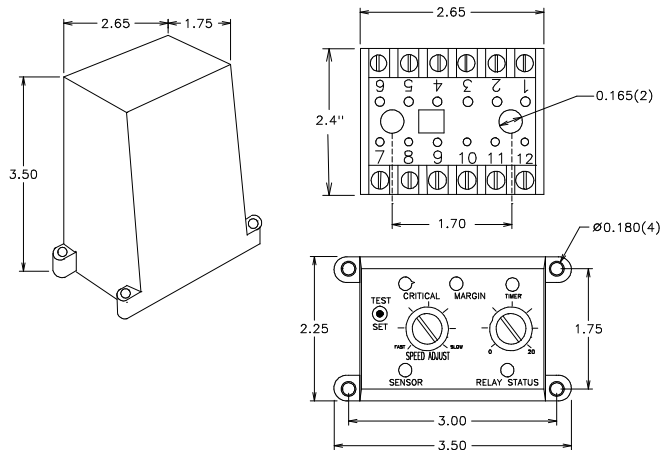

REPLACEMENT AND OPTIONAL PARTS

Control Module	22-8802-2000
Mounting Socket	22-8003
Threaded PVC Proximity Sensor	10-7139
I.S. Threaded PVC Proximity Sensor	10-7039
I.S. Zener Barrier	10-7072

TYPICAL BELT STARTER

TYPICAL BELT STARTER
22-8800 INSTALLATION

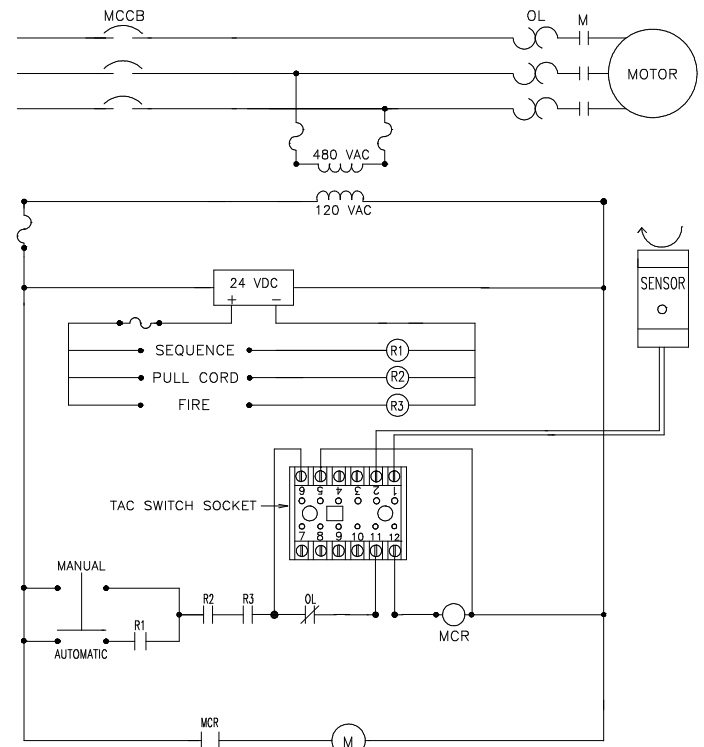

FIGURE 1

DOCUMENT DATE: 17-Apr-02



238 Pillow Street
Butler, PA 16001
(724) 283-4681
Fax (724) 283-5939
www.bwieagle.com