



105 Bonnie Drive  
Butler, PA 16002  
724-283-4681  
724-283-5939 (fax)  
www.bwieagle.com

# PRODUCT INFORMATION BULLETIN

## TAC-SWITCH Critical Speed Switch MODEL 22-8800-220VAC

### BOTE APPROVAL

1207-90

### DESCRIPTION

The model 22-8800-220VAC TAC-SWITCH is one in a series of critical speed switches that monitor speed and detect motion in all types of machinery and apparatus. Complete with ramp-up timer, the 22-8800-220VAC monitors speed ranges of 60 - 800 RPMs. The TAC-SWITCH utilizes a non-contacting proximity sensor that may be remotely located up to two miles from the control unit. Enclosed in durable ABS plastic, the socket mounted control unit conveniently mounts inside an existing electrical panel or O.E.M. control box. Ideal for conveyors, crushers, fans, motors and other rotating apparatus.

### INSTALLATION

Disconnect AC power before proceeding with installation

1. Mount the TAC-SWITCH socket inside an existing control panel or other suitable protective enclosure
2. Make the following connections on the socket:

| TERMINAL | CONNECTION            |
|----------|-----------------------|
| 1        | Sensor - Common (-)   |
| 2        | Sensor - Positive (+) |
| 3        | No Connection         |
| 4        | Earth Ground          |
| 5 - 6    | 220 VAC               |
| 7        | Relay - N/C (1)       |
| 8        | Relay - Common (1)    |
| 9        | Relay - N/O (1)       |
| 10       | Relay - N/C (2)       |
| 11       | Relay - Common (2)    |
| 12       | Relay - N/O (2)       |

3. Install EAGLE PROXIMITY SENSOR at roller or shaft. See sensor installation section.

Note: When 220VAC is applied to the unit, the timer function will energize the control relay. After the time has elapsed, the relay will de-energize unless the belt is running at the set speed. To reset the timer, the 220VAC must be removed.



Model 22-8800 Shown

### CONTROLS AND INDICATORS

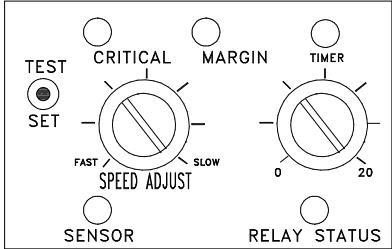

### SET UP AND TESTING

Final calibration should be performed with the belt loaded and running at normal speed.

1. Turn SPEED control CCW until it stops (approximately 7 o'clock)
2. Hold switch in set position to energize relay.
3. Turn SPEED control CW slowly until CRITICAL SPEED LED stays on continuously.
4. Continue turning SPEED control until MARGIN LED begins to blink\*\*\*
5. After RELAY STATUS LED is illuminated, return switch to RUN position (center)
6. A momentary TEST position is provided to simulate the loss of sensor signal which releases the control relay
7. Set timer for desired ramp-up period

\*\*\* Using the above calibration, the control relay will drop out at a machinery slow down of approximately 15% For a 20% margin, adjust the SPEED control so that the MARGIN LED just comes on steady. For a 10% margin, adjust the SPEED control CCW so that the MARGIN LED has just gone out. If a margin greater than 20% is desired, consult BWI Eagle, Inc. For ALL speed adjustments, the CRITICAL SPEED LED must stay on continuously.

# TAC-SWITCH

Critical Speed Switch

**MODEL 22-8800-220VAC**

## SPECIFICATIONS

|                |                            |
|----------------|----------------------------|
| AC Input       | 220VAC 5W                  |
| Fuse Protected | 1 amp                      |
| Speed Range    | 60 - 800 RPM               |
| Relay Contacts | DPDT 5 amp @ 220VAC        |
| Safety Delay   | 1 Second                   |
| Response Time  | 1 Second or Less           |
| Start-up Timer | 1 - 20 Seconds, Adjustable |
| Enclosure      | ABS Plastic                |

## DIMENSIONS

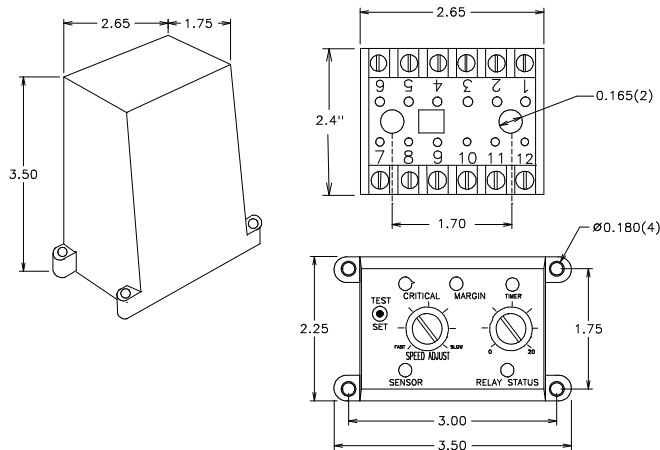

## REPLACEMENT AND OPTIONAL PARTS

|                                    |                |
|------------------------------------|----------------|
| Control Module                     | 22-8802-220VAC |
| Mounting Socket                    | 22-8003        |
| Threaded PVC Proximity Sensor      | 10-7139        |
| I.S. Threaded PVC Proximity Sensor | 10-7039        |
| I.S. Zener Barrier                 | 10-7072        |



238 Pillow Street  
Butler, PA 16001  
(724) 283-4681  
Fax (724) 283-5939  
[www.bwieagle.com](http://www.bwieagle.com)

# PROX SENSOR

Inductive Proximity Type

**MODELS 10-7135, 10-7139, 10-7140**

## INSTALLATION

- Select the roller or shaft to be monitored. If a roller is to be monitored, be sure it is always contacting the belt.
- Affix a target on the roller or shaft. The target should be a piece of key-stock, 1/4-20 Hex Nut, etc. **NOTE:** The use of a notch or a dent is not an acceptable target for the prox sensor. This sensor must see the presence of a target, not an absence of a target as there would be with a notch or dent.
- Mount sensor firmly with hose clamps or U-bolts to prevent it from moving or working loose. Tape is **NOT** recommended as a fastener.
- Before tightening, check that the target passes through the center area of the sensor face. This will produce the greatest sensitivity and sensing distance. With the roller or shaft spinning, move the sensor toward the target. The LED on the sensor should blink in direct proportion to the speed of the shaft or roller. Effective distance between the sensor and target is approximately .1 inch to .5 inch depending on the size of the target.

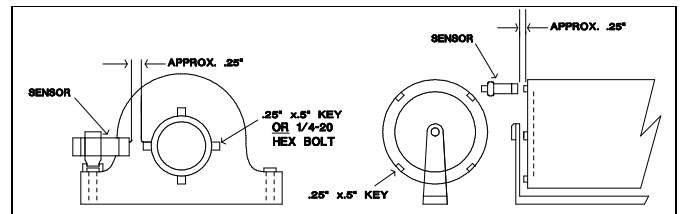

Note: When mounting sensor on small idler rollers (less than 6 inches in diameter), install a maximum of 2 targets

## DIMENSIONS

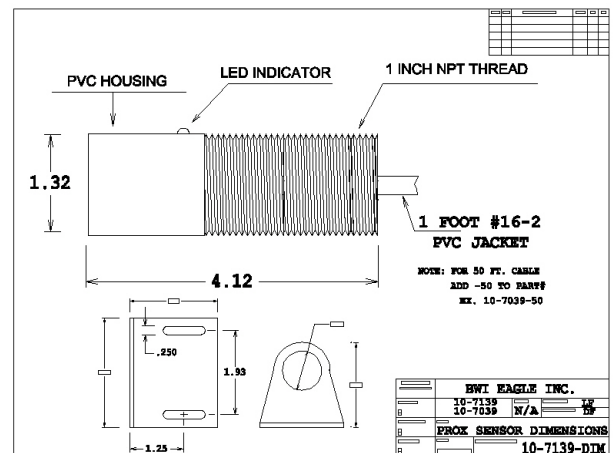

## SPECIFICATIONS

|                          |                                    |
|--------------------------|------------------------------------|
| Dimensions               | 4.12 in. x 1.32 in. O.D.           |
| Sensor Type              | Inductive Proximity (Metal)        |
| Sensor Power Requirement | Current Limited 12VDC from Control |
| Unit Sensor Cable        | Unshielded Twisted Pair 16/2 **    |
| Distance                 | SEE NOTE BELOW                     |
| Distance                 | Sensor to Control Unit - 2 Miles   |
| Minimum Sensing Speed    | Less than 1 RPM                    |

\*\*NOTE - Shielded cable is recommended for all above ground applications. The shield of the cable should be attached to earth ground within 2 feet of the sensor head. In severe noise environments, grounding the shield at the control module also, will eliminate any E.M.I. interference.