



105 Bonnie Drive
Butler, PA 16002
724-283-4681
724-283-5939 (fax)
www.bwieagle.com

PRODUCT INFORMATION BULLETIN

AIR-EAGLE® XLT 900MHz RF Repeater MODEL 44-4500N4W-12VDC

DESCRIPTION

The AIR-EAGLE XLT RF REPEATER IS designed to retransmit an RF signal from any Air-Eagle XLT Transmitter. When placed in an area where the signal is weak, this unit will then re-transmit at full strength facilitating greater distances and allowing the RF signal to reach around corners, through tunnels, over hills and through valleys.

DIMENSIONS & INDICATORS

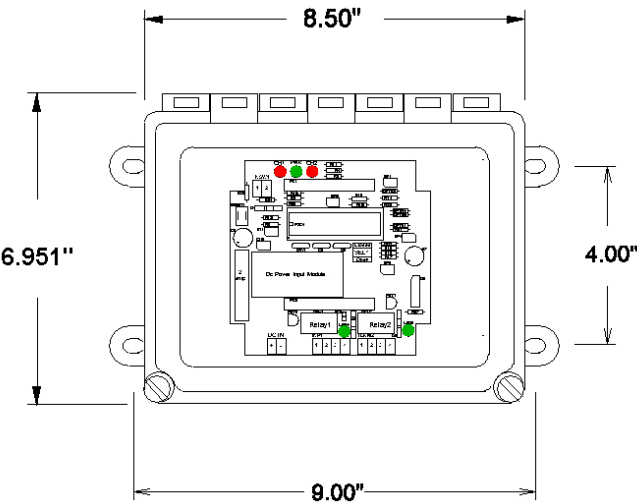

RX LED – Yellow LED illuminates continuously as remote signals are being received by the repeater.

POWER LED – Green LED illuminates continuously while power is applied to the repeater.

TX LED - Red LED illuminates continuously while signals are being re-transmitted from the repeater.



PC BOARD SET-UP INFORMATION

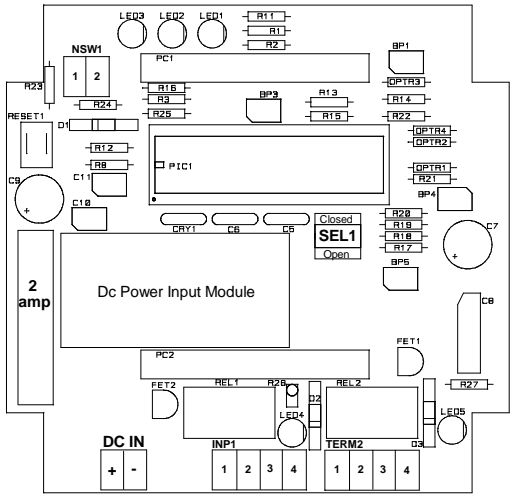

Make the following connections on the PC Board Terminal Strip:

DC INPUT TERMINAL STRIP (DC IN)	
Terminal 1	Positive (+) 12VDC INPUT
Terminal 2	Negative (-) 12VDC INPUT

INPUT 1 TERMINAL STRIP (INP1)	Not Used On This Model
I/O TERMINAL STRIP (TERM2)	Not Used On This Model

NETWORK SWITCH CONFIGURATION OPTIONS (SEL1)			
SEL 1 (SW1 & 2): USED TO SET NETWORK FREQUENCY	Network Address	SW1	SW2
	#1	OPEN	OPEN
	#2	CLOSED	OPEN
	#3	OPEN	CLOSED
	#4	CLOSED	CLOSED

AIR-EAGLE® XLT

900MHz RF Repeater

MODEL 44-4500N4W-12VDC

APPROVALS

United States (FCC)	OUR-9XSTREAM
Canada (IC)	4214A-9XSTREAM

SPECIFICATIONS

Power Supply	9 – 18 VDC Input
Fuse Protected	2 amp
RX/TX Frequency	900MHz Spread Spectrum
Transmit Range	Up to 10 miles with external antenna - see accessories)
Operating Temperature	-40° to +85°
Enclosure	Fiberglass NEMA 4W, 4x, 12 + 13

REPLACEMENT PARTS & ACCESSORIES

PC Board (Main)	44-4502
Optional Transceiver Antennas:	
900MHz Omni Directional Antenna Medium Range Operation – For Ranges Up to 2 miles *	49-3101
900MHz 13dB Yagi Antenna Long Range Operation – For Ranges Greater than 2 miles / Up to 10 miles *	49-3102
Inline Lightning Arrestor	49-5002
* = Line of Sight	

LIMITED WARRANTY STATEMENT

BWI Eagle Inc. warrants the Air-Eagle Remote Control System, if properly used and installed, will be free from defects in material and workmanship for a period of **1 year** after date of purchase. Said warranty to include the repair or replacement of defective equipment. This warranty does not cover damage due to external causes, including accident, problems with electrical power, usage not in accordance with product instructions, misuse, neglect, alteration, repair, improper installation, or improper testing. This limited warranty, and any implied warranties that may exist under state law, apply only to the original purchaser of the equipment, and last only for as long as such purchaser continues to own the equipment. This warranty replaces all other warranties, express or implied including, but not limited to, the implied warranties or merchantability and fitness for a particular purpose. BWI Eagle makes no express warranties beyond those stated here. BWI disclaims without limitation, implied warranties of merchantability and fitness for a particular purpose. Some jurisdictions do not allow the exclusion of implied warranties so this limitation may not apply to you. To obtain warranty service, contact BWI Eagle for a return material authorization. When returning equipment to BWI Eagle, the customer assumes the risk of damage or loss during shipping and is responsible for the shipping costs incurred.

DOCUMENT DATE: 11-Feb-05



105 Bonnie Drive
Butler, PA 16002
(724) 283-4681
Fax (724) 283-5939
www.bwieagle.com