



238 Pillow Street
 Butler, PA 16001
 724-283-4681
 724-283-5939 (fax)
 www.bwieagle.com

PRODUCT INFORMATION BULLETIN

SLIP SWITCH TESTER PA Approved MODEL 50-7200

APPROVAL

PA - 1028-88

INSTALLATION

The unit is supplied with a 15 foot, 5 conductor AC/Control cable and a 15 foot, 2 conductor sensor cable.

1. Remove AC power from the Belt Starter.
2. Mount the unit in a convenient location at the Belt Starter.
3. Locate the motor control relay in the starter box. Install the white and black wires from the 5 conductor cable to the 120 VAC coil terminals on the relay. (see Figure 1)
4. Connect the green control wire to chassis ground in the starter.
5. Connect the orange and red wires directly across the Slip Switch control relay contacts. (see Figure 1)
6. Connect the black and white sensor cable wires in parallel with the existing sensor wiring from the Slip Switch. Be sure to observe polarity. (see Figure 1)
7. Reapply AC power to Belt Starter.

TESTING

NO AC power should be applied to the S.S.T. unless the belt is running. Once the belt is running, the **"POWER"** LED should be the only LED illuminated. If other LED's are on, the reset button must be pushed before the test can be started.

Once the start button is pushed all LED's will illuminate and the **"Alarm Sonalert"** will sound for 1 second. During this time the internal circuitry of the S.S.T. is checked for proper operation.

Next, the **"START"** LED and the **"SENSOR"** LED will illuminate. The **"SENSOR"** LED will go out after approximately 2 seconds. If a jumper is detected in the system it will be indicated at this point in the test. If no jumper is detected in the wiring, the S.S.T. will wait approximately 7 seconds for the control relay of the Slip Switch to re-energize. The **"TEST OK"** LED will then illuminate and the **"START"** LED will go out. The test is now complete.

To test again, the reset button must be pushed, then push the start button to initiate another test.



TYPICAL BELT STARTER

TYPICAL BELT STARTER
 50-7200 S.S.T. Installation

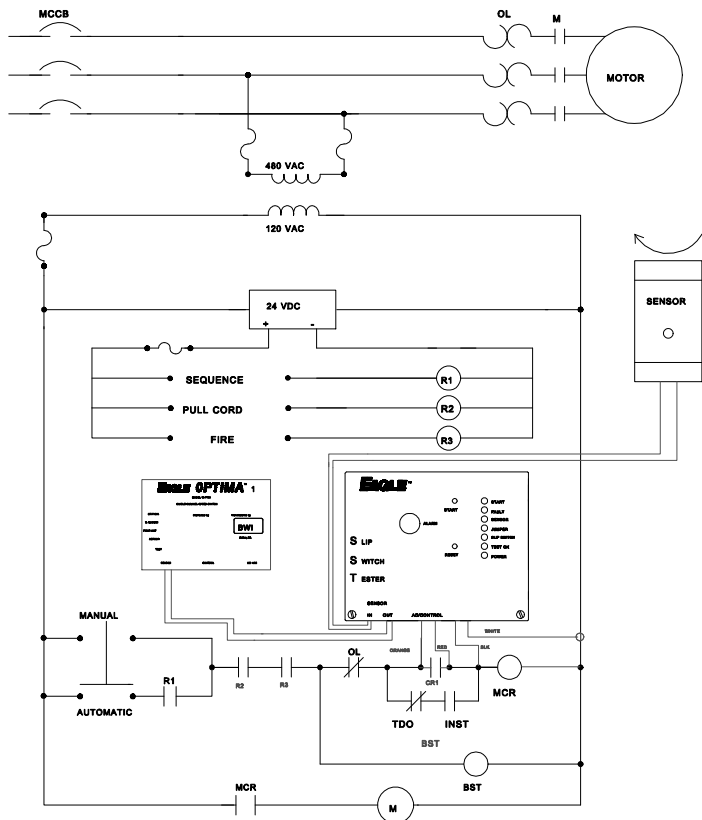

FIGURE 1

SLIP SWITCH TESTER

PA Approved

MODEL 50-7200

CONTROLS AND INDICATORS

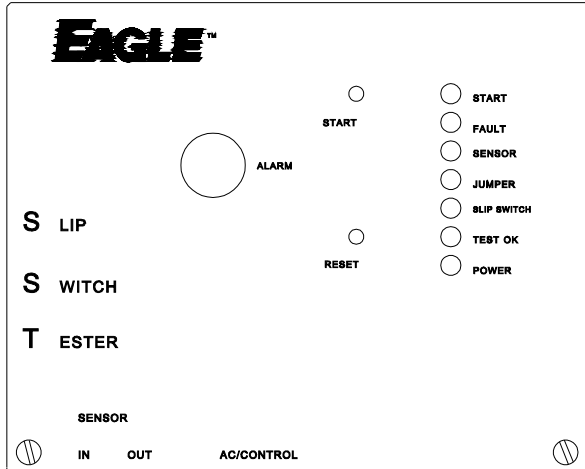

START LED - When illuminated, indicates that the test is in progress.

FAULT LED - When illuminated, indicates that a problem has been detected in the control wiring, or the S.S.T. unit.

SENSOR LED - Illuminates while the sensor of the Slip Switch is being disabled.

JUMPER LED - When illuminated, indicates that a jumper has been detected.

SLIP SWITCH LED - When illuminated, indicates that the belt has begun to slip during the test. The LED will stay illuminated for 5 seconds and then allow the Slip Switch to shut the belt down.

TEST OK LED - When illuminated, indicates that the test is completed and the Slip Switch is operating properly.

POWER LED - When illuminated, indicates that the belt is running and power is applied to the unit.

START PUSH BUTTON - A momentary push button used to initiate the test.

RESET PUSH BUTTON - A momentary push button used to reset the unit from any alarm conditions.

ALARM SONALERT - Gives an audible alarm when any condition other than "Test OK" is encountered during a test.

SPECIFICATIONS

AC Input	120 VAC 15W With Belt Running
Fuse Protected	1 amp
Operating Temperature	-40°C to +60°C (-40° to 140°F)
Testing Current Range	15mA to 550mA AC
Housing	NEMA 12 Standard

DIMENSIONS

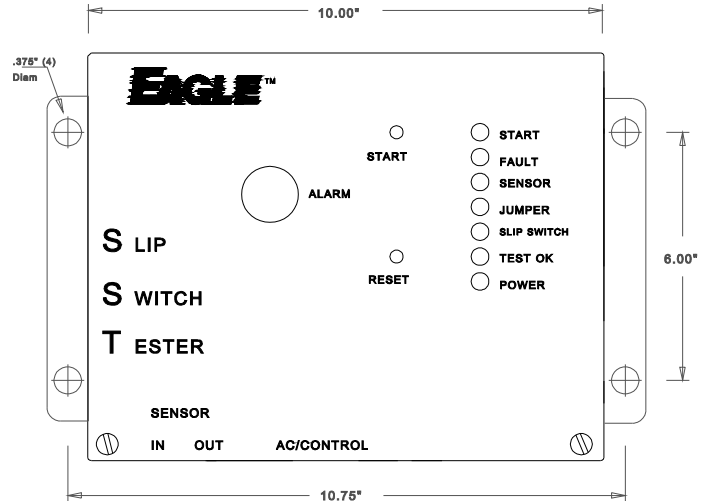

REPLACEMENT PARTS

Main PC Board	50-7201
Display PC Board	50-7202
Computer Interface PC Board	50-7203
Control Cable - 15'	50-7215
Sensor Cable - 15'	50-7204
Sensor Cable - 2' w/Connectors	50-7206

DOCUMENT DATE: 11-Aug-04



238 Pillow Street
Butler, PA 16001
(724) 283-4681
Fax (724) 283-5939
www.bwieagle.com