



105 Bonnie Drive
Butler, PA 16002
724-283-4681
724-283-5939 (fax)
www.bwieagle.com

PRODUCT INFORMATION BULLETIN

AIR-EAGLE® SR PLUS 2.4 GHz RF Transmitter MODEL 36-1200-DC

DESCRIPTION

The AIR-EAGLE SR PLUS TX is an R.F. transmitter designed to send a single stop command to an Air-Eagle SR Receiver from up to 600 feet away. Any number of transmitters and receivers can be combined to create a medium-range remote control system that operates hazardous or hard-to-reach electrical apparatus from safe, convenient locations. This unit has eight user-selectable network frequencies to allow multiple systems to operate simultaneously in the same area without interference.

INSTALLATION

DISCONNECT Power from all equipment before installation.

1. Mount the transmitter in a convenient location.
2. Install antenna onto antenna connector located on the right side on the enclosure.
3. Connect supplied power input cable to your external power source.

TERMINAL STRIP WIRING

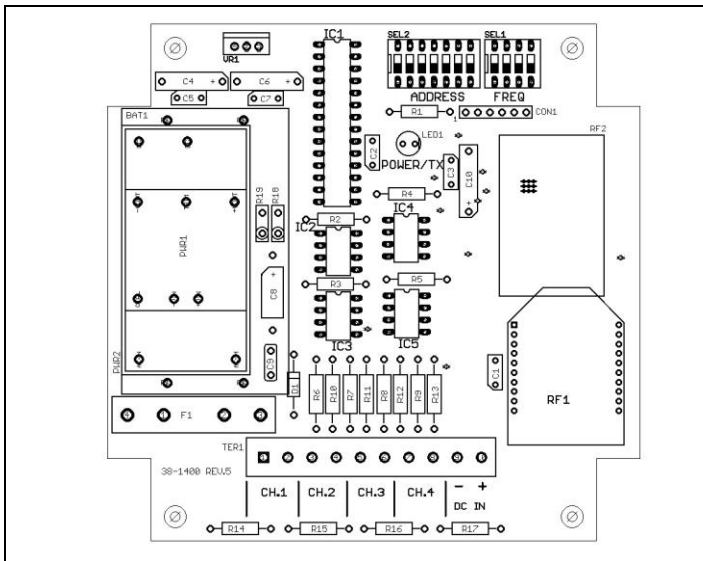

1	2	3	4	5	6	7	8	9	10
E-Stop Button Pre-Wired to Input 1	C Input 2	Input 2	C Input 3	Input 3	C Input 4	Input 4	(-) 9-36VDC input	(+) 9-36VDC input	(+) 9-36VDC input



Dimensions (with mounting plate) 6.3" L x 4.8" W x 4.3" H

CONTROLS & INDICATORS

PWR/TX LED	Illuminates green continuously while power is applied. Changes to red when transmitting data.
STOP Pushbutton	Transmits CH1 RF "STOP" code to receiver
Inputs 2, 3 and 4	Independently transmit CH2, CH3 and CH4 codes to receiver

FREQUENCY SET-UP

The unit is shipped from the factory with all SEL2 switches in the open positions. By default, it is operating on Frequency #1. If you wish to change the frequency, follow the instructions on the table below.

- 1) Remove power from unit and take cover off.
- 2) Select desired frequency using table below.
- 3) Reattach cover and apply power. Programming is now complete.

FREQUENCY SET-UP				
	Network Frequency	SW1	SW2	SW3
SEL1 (SW1-3)	1 (default)	OPEN	OPEN	OPEN
	2	CLOSED	OPEN	OPEN
	3	OPEN	CLOSED	OPEN
	4	CLOSED	CLOSED	OPEN
	5	OPEN	OPEN	CLOSED
	6	CLOSED	OPEN	CLOSED
	7	OPEN	CLOSED	CLOSED

Note – SW4 not used

AIR-EAGLE® SR PLUS

2.4 GHz RF Transmitter

MODEL 36-1200-DC

APPROVALS

United States (FCC)	MCQ-XBEE3
Canada (IC)	1846A-XBEE3
Europe (CE)	ETSI

SPECIFICATIONS

Power Input	9 - 36 VDC @ 10 Watts
Transmit Frequency	2.4GHz Spread Spectrum
RF Output Power	60 mW
Transmit Range	Up to 600 Feet
Note: Max range figures are estimates, based on free-air terrain with limited sources of interference. Actual range will vary based on transmitting power, orientation of transmitter and receiver, height of transmitting antenna, height of receiving antenna, weather conditions, interference sources in the area, and terrain between receiver and transmitter, including, but not limited to, indoor and outdoor structures such as walls, metal objects, trees, buildings, hills, and mountains.	
Transmit Data Channels	Four Dry Contact Input
RF Networks	Eight Independent Frequencies
Antenna Connection	TNC Female
Enclosure	Polycarbonate, NEMA 4, IP66
Operating Temperature	-40° F to +185° F
Weight	Approx 1.82 lbs.

ACCESSORIES

Standard Antenna (Included):	
2.4GHz TNC "Rubber Duck" Antenna	49-1201
Mobile/Base Antennas – Used to help achieve max range in both non line of sight and line of sight applications. - Contact BWI Eagle for recommendations	
2.4GHz Thru-Hole Mount Mobile Antenna	49-2201
2.4GHz Magnet Mount Mobile Antenna	49-2202
2.4GHz Omni Directional Base Antenna	49-3201
2.4GHz Yagi Directional Base Antenna	49-3202
High Quality Coax Cables – Used to connect external high gain antennas to control unit	
Flex Coax Cable w/Connectors – Available in 5', 15', 25', 30', 40', 60', 80', 100' Lengths	49-4000-XX (XX = # of Feet)
Bulkhead Extensions – Used to provide an external antenna connection when mounting control unit inside another enclosure	
TNC Male to TNC Bulkhead Cable Assembly - Available in 2', 4', 7' Lengths	49-5004-X-ISO (X = # of Feet)

LIMITED WARRANTY STATEMENT

BWI Eagle Inc. warrants the Air-Eagle Remote Control System, if properly used and installed, will be free from defects in material and workmanship for a period of 1 year after date of purchase. Said warranty to include the repair or replacement of defective equipment. This warranty does not cover damage due to external causes, including accident, problems with electrical power, usage not in accordance with product instructions, misuse, neglect, alteration, repair, improper installation, or improper testing. This limited warranty, and any implied warranties that may exist under state law, apply only to the original purchaser of the equipment, and last only for as long as such purchaser continues to own the equipment. This warranty replaces all other warranties, express or implied including, but not limited to, the implied warranties of merchantability and fitness for a particular purpose. BWI Eagle makes no express warranties beyond those stated here. BWI disclaims without limitation, implied warranties of merchantability and fitness for a particular purpose. Some jurisdictions do not allow the exclusion of implied warranties so this limitation may not apply to you. To obtain warranty service, contact BWI Eagle for a return material authorization. When returning equipment to BWI Eagle, the customer assumes the risk of damage or loss during shipping and is responsible for the shipping costs incurred.

DOCUMENT DATE: 07/21/2021 / PRODUCT REV. 6



105 Bonnie Drive
Butler, PA 16002
(724) 283-4681
Fax (724) 283-5939
www.bwieagle.com



105 Bonnie Drive
 Butler, PA 16002
 724-283-4681
 724-283-5939 (fax)
 www.bwieagle.com

DRY CONTACT INPUT WIRING 4-Input Transmitter

Standard wiring of a dry contact input transmitter

Shorting together the contacts of the respective channel will cause it to transmit. This can be done with any type of manual or automatic switch.

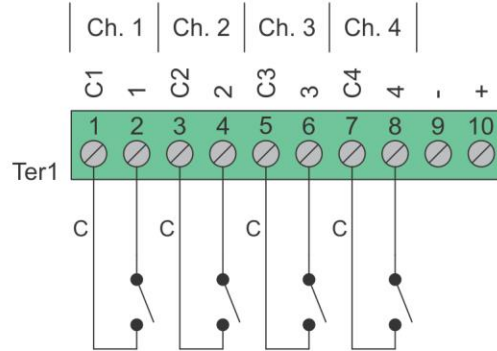

Standard Wiring for Common Ground Applications

Because each channel shares a common (C) terminal, inputs can be wired as shown to allow for fewer conductors to be run to the transmitter.

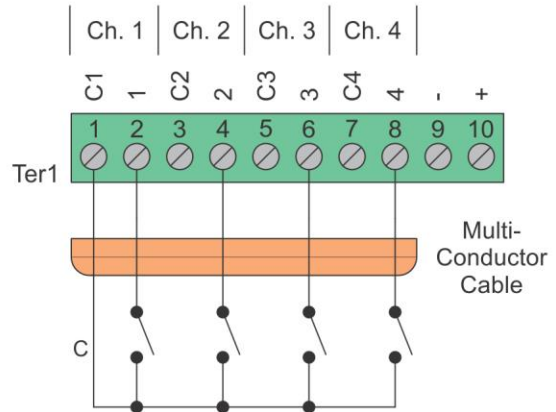

SPDT Switches

The common (C) terminal of the switch only needs to be connected to one of the channels ground terminal. In this configuration two channels would be transmitting all the time. A switch with a center "off" position would allow transmitting to stop. In this example channels 2 and 4 are transmitting.

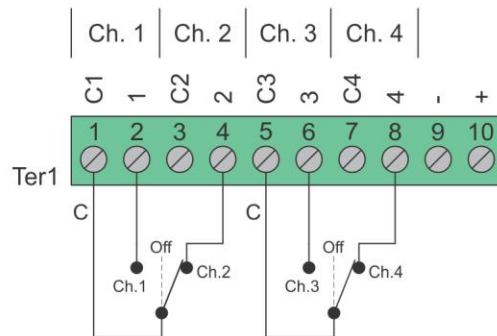

Wiring configurations shown here are examples. The wiring for your application may differ.
 Call BWI Eagle for assistance or consult an electrician.