



105 Bonnie Drive
Butler, PA 16002
724-283-4681
724-283-5939 (fax)
www.bwieagle.com

PRODUCT INFORMATION BULLETIN

AIR-EAGLE® SR PLUS 2.4GHz 20 Dry Contact Input Transmitter MODEL 36-12000-DC

DESCRIPTION

The AIR-EAGLE SR PLUS TX is an R.F. transmitter capable of sending twenty independent dry contact input commands to an Air-Eagle SR Receiver from up to 600 feet away. Any number of transmitters and receivers can be combined to create a medium-range remote control system that operates hazardous or hard-to-reach electrical apparatus from safe, convenient locations. This unit has eight user-selectable network frequencies to allow multiple systems to operate simultaneously in the same area without interference.

INSTALLATION

DISCONNECT Power from all equipment before installation.

1. Mount the transmitter in a convenient location.
2. Install input wiring to terminal strip.
3. Install antenna onto antenna connector located on the right side on the enclosure.
4. Connect supplied power input cable to your external power source.

DIGITAL FREQUENCY SET-UP

This transmitter is factory programmed to Frequency #1. This setting can be changed by the user at any time **but must match the corresponding receiver(s)**.

<ol style="list-style-type: none"> 1) Remove power from unit 2) Open hinged cover. 3) Select desired network frequency using table below. 4) Reattach cover and apply power. 5) Programming is now complete. 				
SEL1 (SW 1-4)	Not used on this model			
SEL 1 (SW 5-7): (NETWORK FREQUENCY)	Network Frequency	SW5	SW6	SW7
	1 (default)	OPEN	OPEN	OPEN
	2	CLOSED	OPEN	OPEN
	3	OPEN	CLOSED	OPEN
	4	CLOSED	CLOSED	OPEN
	5	OPEN	OPEN	CLOSED
	6	CLOSED	OPEN	CLOSED
	7	OPEN	CLOSED	CLOSED
	8	CLOSED	CLOSED	CLOSED

GENERAL OPERATION

A closure on any input transmits its channel command to activate the corresponding relay in the remote receiver. The transmission continues as long as the input is closed and ceases when the input opens.



Dimensions 8" L x 6" W x 4" H

TERMINAL STRIP WIRING

BOTTOM TERMINAL BLOCK			
1	C Input #1	11	C Input #6
2	Input #1	12	Input #6
3	C Input #2	13	C Input #7
4	Input #2	14	Input #7
5	C Input #3	15	C Input #8
6	Input #3	16	Input #8
7	C Input #4	17	C Input #9
8	Input #4	18	Input #9
9	C Input #5	19	C Input #10
10	N/O Input #5	20	N/O Input #10
TOP TERMINAL BLOCK			
1	C Input #11	11	C Input #16
2	Input #11	12	Input #16
3	C Input #12	13	C Input #17
4	Input #12	14	Input #17
5	C Input #13	15	C Input #18
6	Input #13	16	Input #18
7	C Input #14	17	C Input #19
8	Input #14	18	Input #19
9	C Input #15	19	C Input #20
10	Input #15	20	Input #20
DC INPUT TERMINAL BLOCK			
1	(-) 9-36VDC Input	2	(+) 9-36VDC Input

AIR-EAGLE® SR PLUS

2.4 GHz 8 Input RF Transmitter

MODEL 36-12000-120VAC

CONTROLS AND INDICATORS

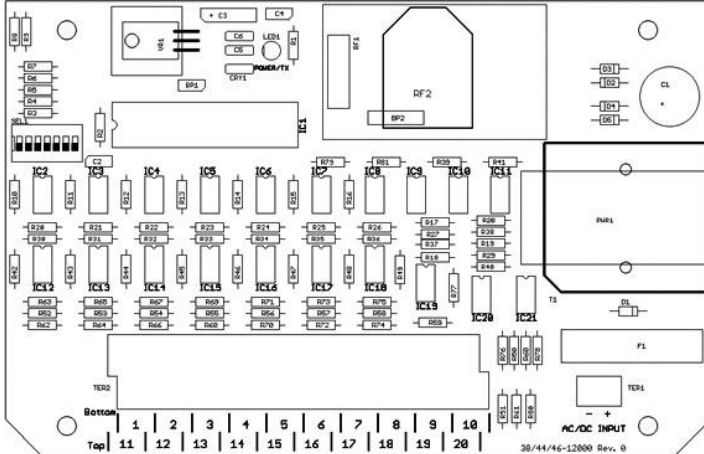

LED1	Illuminated green when power is applied. Changes to red when transmitting data.
Inputs 1 thru 20	Twenty dry contact inputs

APPROVALS

United States (FCC)	MCQ-XBEE3
Canada (IC)	1846A-XBEE3
Europe (CE)	ETSI

SPECIFICATIONS

Power Input	9 - 36 VDC @ 10 Watts
Fuse Protected	1 amp
RF Frequency	2.4 GHz Spread Spectrum
Input Channels	20 Dry Contact Inputs
RF Output Power	60 mW
Transmitter Range	Up to 600 Feet
<p>Note: Max range figures are estimates, based on free-air terrain with limited sources of interference. Actual range will vary based on transmitting power, orientation of transmitter and receiver, height of transmitting antenna, height of receiving antenna, weather conditions, interference sources in the area, and terrain between receiver and transmitter, including, but not limited to, indoor and outdoor structures such as walls, metal objects, trees, buildings, hills, and mountains</p>	
RF Networks	Eight Independent Frequencies
Antenna Connection	TNC Bulkhead
Enclosure	Fiberglass / NEMA 4, 4x, 12 + 13
Operating Temperature	-40° F to +185° F

ACCESSORIES

Standard Antenna (Included):	
2.4GHz TNC "Rubber Duck" Antenna	49-1201
Mobile/Base Antennas – Used to help achieve max range in both non line of sight and line of sight applications. - Contact BWI Eagle for recommendations	
2.4GHz Thru-Hole Mount Mobile Antenna	49-2201
2.4GHz Magnet Mount Mobile Antenna	49-2202
2.4GHz Omni Directional Base Antenna	49-3201
2.4GHz Yagi Directional Base Antenna	49-3202
High Quality Coax Cables – Used to connect external high gain antennas to control unit	
Flex Coax Cable w/Connectors – Available in 5', 15', 25', 30', 40', 60', 80', 100' Lengths	49-4000-XX (XX = # of Feet)
Bulkhead Extensions – Used to provide an external antenna connection when mounting control unit inside another enclosure	
TNC Male to TNC Bulkhead Cable Assembly - Available in 2', 4', 7' Lengths	49-5004-X-ISO (X = # of Feet)

LIMITED WARRANTY STATEMENT

BWI Eagle Inc. warrants the Air-Eagle Remote Control System, if properly used and installed, will be free from defects in material and workmanship for a period of 1 year after date of purchase. Said warranty to include the repair or replacement of defective equipment. This warranty does not cover damage due to external causes, including accident, problems with electrical power, usage not in accordance with product instructions, misuse, neglect, alteration, repair, improper installation, or improper testing. This limited warranty, and any implied warranties that may exist under state law, apply only to the original purchaser of the equipment, and last only for as long as such purchaser continues to own the equipment. This warranty replaces all other warranties, express or implied including, but not limited to, the implied warranties or merchantability and fitness for a particular purpose. BWI Eagle makes no express warranties beyond those stated here. BWI disclaims without limitation, implied warranties of merchantability and fitness for a particular purpose. Some jurisdictions do not allow the exclusion of implied warranties so this limitation may not apply to you. To obtain warranty service, contact BWI Eagle for a return material authorization. When returning equipment to BWI Eagle, the customer assumes the risk of damage or loss during shipping and is responsible for the shipping costs incurred.

DOCUMENT DATE: 07/21/2021 / PRODUCT REV. 1



105 Bonnie Drive
Butler, PA 16002
(724) 283-4681
Fax (724) 283-5939
www.bwieagle.com



105 Bonnie Drive
Butler, PA 16002
724-283-4681
724-283-5939 (fax)
www.bwieagle.com

DRY CONTACT INPUT WIRING 20-Input Transmitter

Standard wiring of a dry contact input transmitter

Shorting together the contacts of the respective channel will cause it to transmit. This can be done with any type of manual or automatic switch.

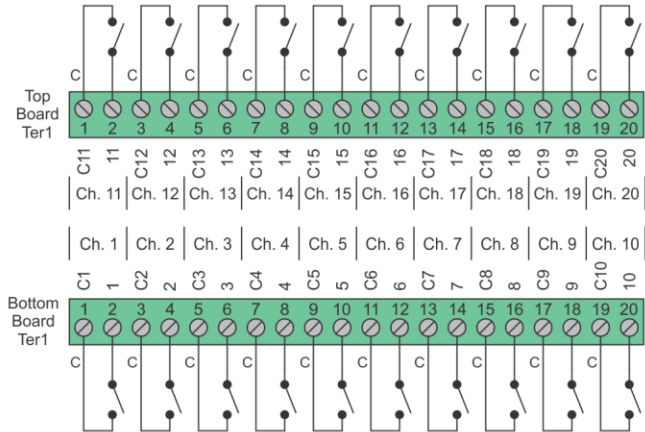

Standard Wiring for Common Ground Applications

Because each channel shares a common (C) terminal, inputs can be wired as shown to allow for fewer conductors to be run to the transmitter.

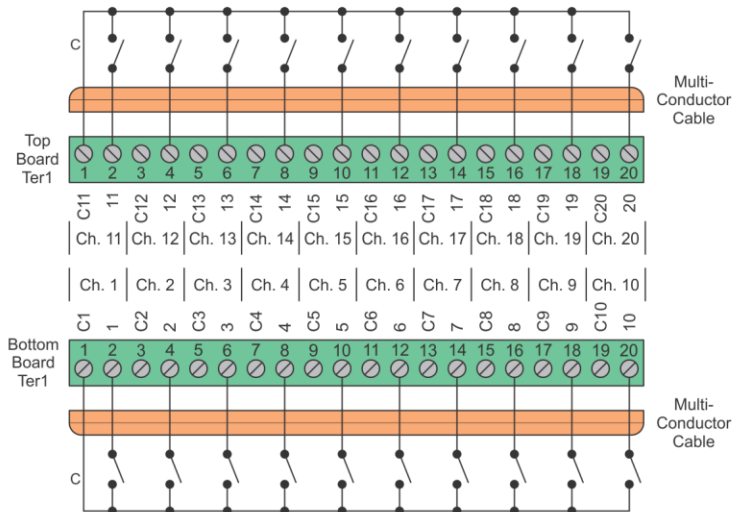

SPDT Switches

The common (C) terminal of the switch only needs to be connected to one of the channels ground terminal. In this configuration ten channels would be transmitting all the time. A switch with a center "off" position would allow transmitting to stop.

In this example channels 2, 4, 6, 8, 10, 12, 14, 16, 18, and 20 are transmitting.

