

EAGLE VR SENSOR

10-7003

10-7003-3

10-7003-3P

10-7003-6

Variable Reluctance Type



Document Date: 11/26/2024

Product Rev: 1

PIB No: 9M02-10-7003



cattron.com/products/bwi-eagle



655 N River Rd NW, Suite A
Warren, OH 44483

724-283-4681
sales.bwieagle@cattron.com

WARRANTY STATEMENT

Cattron warrants the Air-Eagle Remote Control System, if properly used and installed, will be free from defects in material and workmanship for a period of 1 year after date of purchase. Said warranty to include the repair or replacement of defective equipment. This warranty does not cover damage due to external causes, including accident, problems with electrical power, usage not in accordance with product instructions, misuse, neglect, alteration, repair, improper installation, or improper testing. This limited warranty, and any implied warranties that may exist under state law, apply only to the original purchaser of the equipment, and last only for as long as such purchaser continues to own the equipment. This warranty replaces all other warranties, express or implied including, but not limited to, the implied warranties or merchantability and fitness for a particular purpose. Cattron makes no express warranties beyond those stated here. Cattron disclaims without limitation, implied warranties of merchantability and fitness for a particular purpose. Some jurisdictions do not allow the exclusion of implied warranties so this limitation may not apply to you. To obtain warranty service, contact Cattron for a return material authorization. When returning equipment to Cattron, the customer assumes the risk of damage or loss during shipping and is responsible for the shipping costs incurred.

SIGNAL RANGE

Max range statements are estimates based on a clear line of sight with few interferences. Actual range will vary based on transmitting power, orientation of transmitter and receiver, height of transmitting and receiving antennas, weather conditions, electronic interference, terrain, and physical obstacles, including but not limited to; walls, building structures, trees (foliage), metal objects, and landscape (hills, mountains).



WIRELESS STOP, ASTOP, and E-STOP SYSTEMS

Wireless E-STOP systems should never be considered a primary life-saving device. At least one hard-wired switch must be available in the event the wireless system is not operational. Failure to comply may result in serious injury or death to personnel and damage to equipment.

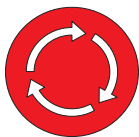

Wireless STOP and ASTOP transmitters are not failsafe emergency stop controls. They are NOT to be used as a life-saving device. They are designed for wireless control of equipment or vehicle remote operation. Failure to use as intended may result in serious injury or death to personnel and damage to equipment.



SCAN ME



INTRODUCTION

The Eagle Variable Reluctance (VR) Sensor is designed to measure signals from any rotating apparatus and transmit this information by low-voltage 2-conductor twisted pair cable to an Eagle control unit located up to 2 miles away. The VR type sensor is identifiable by the bright red end caps.

THEORY OF OPERATION

The Eagle Variable Reluctance sensor detects a target as it passes through the magnetic field of the internal pick-up coil.

The target needs to break the magnetic field fast enough to create an induced voltage in the coil. The minimum sensing speed is approximately 60 RPM.

*Note: Adding additional targets will not increase the minimum sensing speed of the sensor.

The sensing distance from a target is directly proportional to the speed of the roller. For example, at 60 RPM the sensor will detect a 1/2" target at approximately 1/64". At 100 RPM the sensor will detect the same target at approximately 1/4".

SPECIFICATIONS

	10-7003	10-7003-3	10-7003-3P	10-7003-6
Sensor Cable	Unshielded Twisted Pair 16/2			
Cable End	Connector	Connector	Pigtail (no connector)	Connector
Cable Length	50 Ft.	3 Ft.	3 Ft.	6 Ft.
Sensor Type	Variable Reluctance Failsafe Output			
Housing / Mounting	PVC / General Mount			
Sensor Power Requirement	Current limited 12 VDC from Control Unit			
Distance	Sensor to Control Unit - 2 Miles MAX			
Sensing Speed Range	60 RPM – 800 RPM			

INSTALLATION

1. Select the roller or shaft to be monitored. Rollers must always be in contact with belt.
2. Install a target on the roller or shaft. Target can be a piece of key stock, 1/4-20 Hex Nut, or a similar item. Dents and notches are not recommended as targets.
3. Mount sensor firmly with hose clamps or U-bolts to prevent movement or loosening. Tape is not recommended as a fastener.
4. Before tightening, place the sensor close enough to the target(s) to produce a strong, steady blinking on the sensor LED. The LED will blink in direct proportion to the shaft/roller speed. Effective distance between the sensor and target is approximately 1/2" depending on target mass and roller speed.

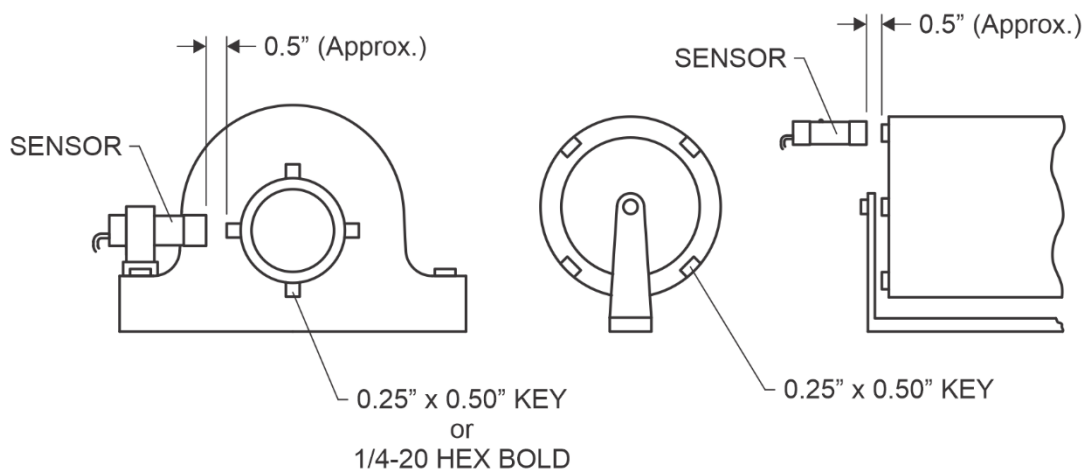

DIMENSIONS

Note: Some models supplied with connector shown below. Other models supplied with pigtail cable end (no connector). See SPECIFICATIONS section.

