

# EAGLE I.S. PROX SENSOR

**10-7039**

**10-7039-25**

**10-7039-50**

**10-7039-50-SJO**

**10-7039-ST2**

**Intrinsically Safe  
Inductive Proximity Type**

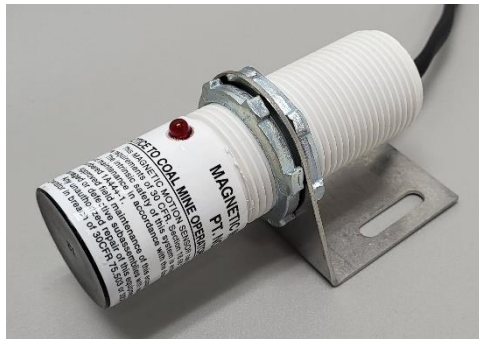

**Document Date:** 12/04/2024

**Product Rev:** 1

**PIB No:** 9M02-10-7039



[cattron.com/products/bwi-eagle](http://cattron.com/products/bwi-eagle)



655 N River Rd NW, Suite A  
Warren, OH 44483

724-283-4681  
[sales.bwieagle@cattron.com](mailto:sales.bwieagle@cattron.com)

## WARRANTY STATEMENT

Cattron warrants the Air-Eagle Remote Control System, if properly used and installed, will be free from defects in material and workmanship for a period of 1 year after date of purchase. Said warranty to include the repair or replacement of defective equipment. This warranty does not cover damage due to external causes, including accident, problems with electrical power, usage not in accordance with product instructions, misuse, neglect, alteration, repair, improper installation, or improper testing. This limited warranty, and any implied warranties that may exist under state law, apply only to the original purchaser of the equipment, and last only for as long as such purchaser continues to own the equipment. This warranty replaces all other warranties, express or implied including, but not limited to, the implied warranties or merchantability and fitness for a particular purpose. Cattron makes no express warranties beyond those stated here. Cattron disclaims without limitation, implied warranties of merchantability and fitness for a particular purpose. Some jurisdictions do not allow the exclusion of implied warranties so this limitation may not apply to you. To obtain warranty service, contact Cattron for a return material authorization. When returning equipment to Cattron, the customer assumes the risk of damage or loss during shipping and is responsible for the shipping costs incurred.

## SIGNAL RANGE

Max range statements are estimates based on a clear line of sight with few interferences. Actual range will vary based on transmitting power, orientation of transmitter and receiver, height of transmitting and receiving antennas, weather conditions, electronic interference, terrain, and physical obstacles, including but not limited to; walls, building structures, trees (foliage), metal objects, and landscape (hills, mountains).



## WIRELESS STOP, ASTOP, and E-STOP SYSTEMS

Wireless E-STOP systems should never be considered a primary life-saving device. At least one hard-wired switch must be available in the event the wireless system is not operational. Failure to comply may result in serious injury or death to personnel and damage to equipment.

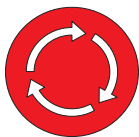

Wireless STOP and ASTOP transmitters are not failsafe emergency stop controls. They are NOT to be used as a life-saving device. They are designed for wireless control of equipment or vehicle remote operation. Failure to use as intended may result in serious injury or death to personnel and damage to equipment.



SCAN ME



## INTRODUCTION

The Eagle Inductive Proximity Sensor is designed to measure signals from any rotating apparatus and transmit this information by low-voltage 2-conductor twisted pair cable to an Eagle control unit located up to 2 miles away. The sensor's technology is further enhanced with circuitry to reduce or eliminate the adverse effects of electrical noise.

## THEORY OF OPERATION

The Eagle Inductive Proximity sensor detects a target as it approaches the internal oscillator coil encapsulated in the sensor head. When the target approaches the front of the coil, it causes a decrease in the amplitude of the oscillator. This damping effect can be sensed at any RPM. The sensor can read speeds below 1 RPM and as high as several thousand RPMs.

The sensing distance from a target is approximately 1/8" at any speed. This spacing eliminates missed targets as monitored speed increases and decreases.

## SPECIFICATIONS

	10-7039	10-7039-25	10-7039-50	10-7039-50-SJO	10-7039-ST2
<b>Sensor Cable</b>	Unshielded Twisted Pair 16/2			SJO 16/2	MSHA
<b>Cable Length</b>	3 Ft.	25 Ft.	50 Ft.	50 Ft.	16"-18"
<b>Cable End</b>	Pigtail (no connector)				
<b>Sensor Type</b>	Inductive Proximity (Metal)				
<b>Housing / Mounting</b>	Threaded PVC / Conduit or Bracket Mounting				
<b>Sensor Power Requirement</b>	Current limited 12 VDC from Zener Barrier				
<b>Distance</b>	Sensor to Control Unit - 1 Mile MAX				
<b>Sensing Speed Range</b>	Less than 1 RPM – 6000 RPM				

## INSTALLATION

1. Select the roller or shaft to be monitored. Rollers must always be in contact with belt.
2. Install a target on the roller or shaft. Target can be a piece of key stock, 1/4-20 Hex Nut, or a similar item. Dents and notches are not recommended as targets.
3. Mount sensor firmly with threaded conduit, included bracket, hose clamps, or U-bolts to prevent movement or loosening. Tape is not recommended as a fastener.
4. Before tightening, place the sensor close enough to the target(s) to produce a strong, steady blinking on the sensor LED. The LED will blink in direct proportion to the shaft/roller speed. Effective distance between the sensor and target is approximately 1/2" depending on target mass and roller speed.

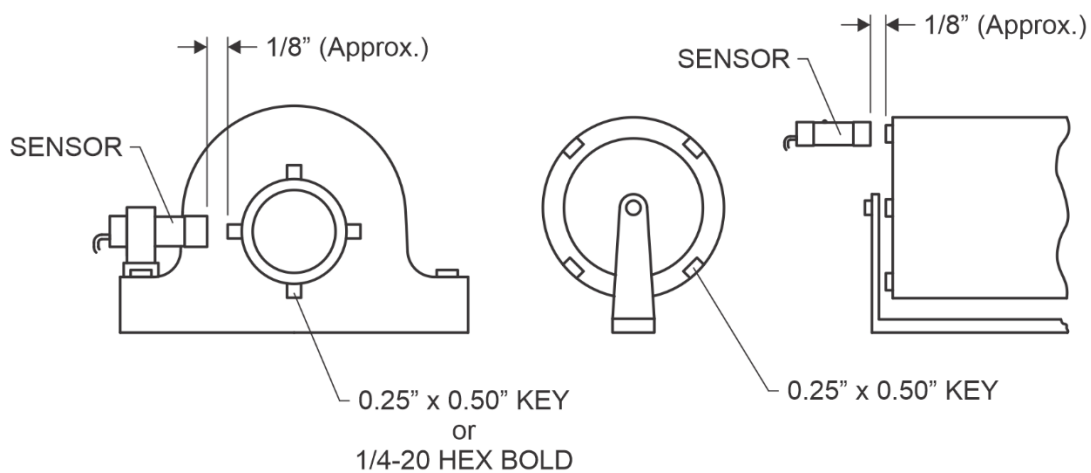

Note: When mounting sensor on small idler rollers (less than 6" diameter), install a maximum of 2 targets.

Note: Shielded cable is recommended for all above ground applications. Attach the shield of the cable to earth ground within 2 feet of the sensing head. In severe noise environments, also grounding the shield at the control module will eliminate any E.M.I. interference. See SPECIFICATIONS section.

## APPROVALS

MSHA	IA444-1
PA	BISC 121-94

**DIMENSIONS**

