



105 Bonnie Drive
Butler, PA 16002
724-283-4681
724-283-5939 (fax)
www.bwieagle.com

PRODUCT INFORMATION BULLETIN

EAGLE 2 Dual Channel Critical Speed Switch MODEL 11-7000 PA BOTE APPROVAL: 1084-89

DESCRIPTION

The EAGLE 2, Model 11-7000 monitors speed and detects motion in all types of rotating electrical apparatus. Two independent channels allow a variety of control functions to meet virtually any application requirement for under-speed or zero speed detection from 6 RPM up to 800 RPM. Its rugged NEMA enclosure is well-suited to meet the environmental challenges of any industry. Ideal for conveyors, crushers, fans, motors and other rotating apparatus.

INSTALLATION

DISCONNECT AC Power before proceeding with instructions.

1. Mount the EAGLE 2 control unit in a convenient location.
2. Make the following connections:
 - A. Connect power cable to 120 VAC.
 - B. Connect control cables to proper terminals in the motor control circuit.
 - C. Connect EAGLE VR SENSOR cables to the sensor connectors on the control unit.
3. Install sensors at rollers. See sensor installation sheet.

SETUP AND TESTING

Final calibration should be performed with the belt loaded and running at normal speed.

1. Turn SPEED ADJUST potentiometer (SPD1) CCW until it stops (approximately 7 o'clock).
2. Hold SW1 switch in SET* position to energize relay.
3. Turn SPEED ADJUST pot CW SLOWLY until CRITICAL SPEED LED stays on continuously.
4. Continue turning SPEED ADJUST pot CW until MARGIN LED begins to blink. **
5. After RELAY LED is illuminated, return switch to RUN position.
6. There is a "safety delay" built into all EAGLE units. This delay leaves the control relay un-energized for 2.5 seconds after critical speed has been achieved to prevent false machinery actuation during maintenance or assembly. For the Eagle 3, channel 1 is adjustable from 0 – 10 seconds using TMR1.
7. Return switch to RUN position.
8. A momentary TEST* position is provided to simulate the loss of sensor signal which releases the control relay.
9. Repeat steps 1 through 8 using the appropriate channel potentiometer (SPD) and test/set switch (SW) for remaining sensor adjustments.

* TEST position is up and SET position is down

** Using the above calibration, the control relay will drop out at a machinery slowdown of approximately 15%. For a 20% MARGIN, adjust the SPEED ADJUST control so that the MARGIN LED just comes on steady. For a 10% MARGIN, adjust the SPEED ADJUST control CCW so that the MARGIN LED has just gone out.



CONTROLS AND INDICATORS

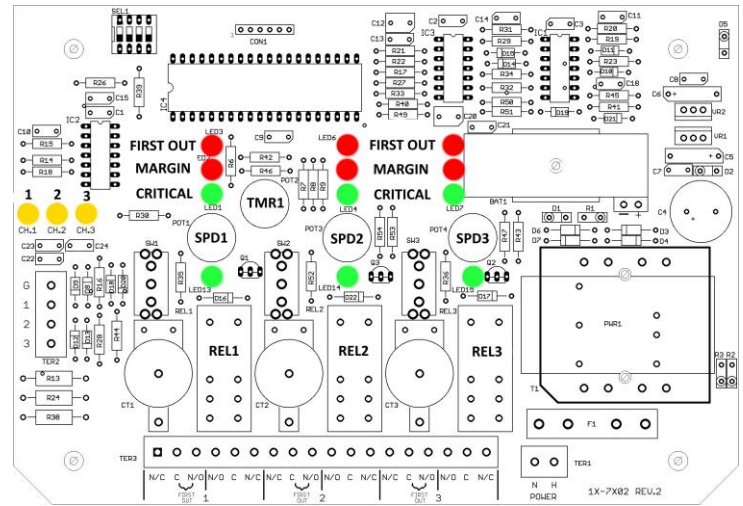

SENSOR LEDs (CH1, CH2, CH3)	Sensor LEDs blink when targets are seen by corresponding sensor
CRITICAL LEDs	Critical speed LEDs illuminate when target speed is => setpoint. These LEDs must be on continuously for control relay to energize
MARGIN LEDs	Indicates percentage of slip (slow down) the channel is calibrated for (Off = 10%; Blinking = 15%; Solid = 20%)
FIRST OUT LEDs	Indicates that the channel shut down due to speed going below set point. If the LED is off then something external caused the belt to shut off (OPTIMA mode ONLY)
RELAY LEDs (LED13, LED14, LED15)	Illuminates when corresponding control relay is energized
SPD1, SPD2, SPD3	Speed adjust potentiometer for channels 1, 2 & 3 respectively
TMR1	Channel 1 relay on-delay potentiometer Adjustable from 0 – 10 seconds (Eagle 3 only)

Note – Not all models will have the controls & indicators shown above

EAGLE 2

Dual Channel Critical Speed Switch

MODEL 11-7000

FIRST OUT OPERATION

The EAGLE OPTIMA "First Out" capability enables the user to visually see (by an LED indicator) if the slip switch relay contacts were the first to open. Once the belt is running and the control relay in the OPTIMA unit has energized, the First-Out indication (if activated) will extinguish. If the belt begins to slip and the OPTIMA unit shuts the drive down, the First-Out LED will illuminate. This LED will stay lit until the belt is restarted and the control relay in the Optima has energized. If R1, R2, or R3 (See TYPICAL BELT STARTER) would open, this would shut the drive down and also the slip switch contacts would open. But, the First-Out LED would not be illuminated. This would allow the user to see that the slip switch relay contacts were not the first to open and cause the shutdown.

DIP SWITCH SETTINGS

Speed Setting	SW1	SW2	SW3
60-800 RPM (default)	OPEN	OPEN	Reserved for future use
6-60 RPM (ALS6) *	CLOSED	OPEN	
15-100 RPM (ALS15) *	OPEN	CLOSED	
25-200 RPM (ALS25) *	CLOSED	CLOSED	

* Proximity Sensor Required for Proper Operation

Eagle/Optima Settings		
	OPEN	CLOSED
SW4	Eagle Unit	Optima Unit

EAGLE/OPTIMA SETTINGS

If switch 4 is open, then the unit is set to operate as a standard Eagle unit. The First Out LED will not operate in this mode. If switch 4 is closed, then the unit is set to operate as an Optima unit. In this mode the external control circuit should be wired through the set of contacts labelled "First Out" on the wiring chart. If the speed drops below the set point that was calibrated during setup, then the relay will turn off and the First Out LED will illuminate. If an external action caused the belt to shut down (i.e. pull cord, loose wire, external shutoff) then the First Out LED will be off when the relay opens.

TERMINAL STRIP WIRING

TER3					
CHANNEL 1		CHANNEL 2		CHANNEL 3	
1	N/C	7	N/C	13	Not Used
2	C (FIRST OUT)	8	C (FIRST OUT)	14	Not Used
3	N/O (FIRST OUT)	9	N/O (FIRST OUT)	15	Not Used
4	N/O	10	N/O	16	Not Used
5	C	11	C	17	Not Used
6	N/C	12	N/C	18	Not Used

TER1	
120VAC	
1	120VAC Neutral
2	120VAC Hot

DIMENSIONS

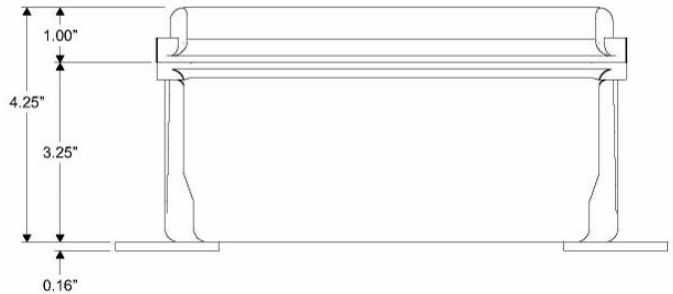
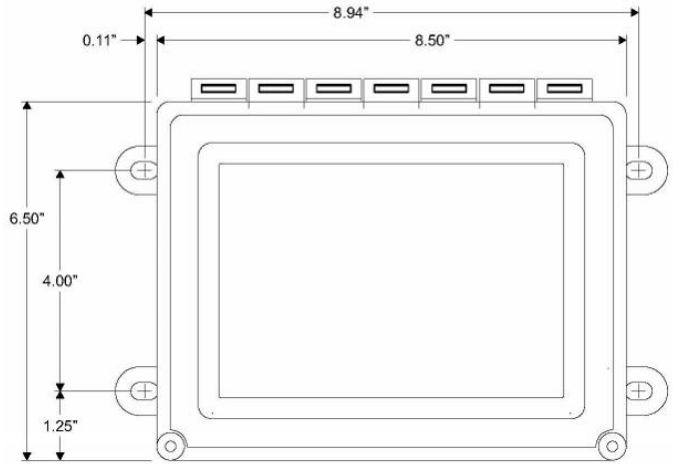

SPECIFICATIONS

AC Input	120 VAC 15 W
Fuse Protected	1 amp
Operating Temperature	-40°C - +60°C (-40° - +140°F)
Speed Range	60 - 800 RPM
Relay Contacts	DP/DT 5 amp @ 120 VAC
First-Out AC Current Range	17mA - 5 amps
Safety Delay - Ch.1 & 2	2.5 Seconds
Response Time	1 Second or Less
Enclosure	Hinged fiberglass with window / NEMA 4, IP66

REPLACEMENT AND OPTIONAL PARTS

P.C. Board	11-7002
Variable Reluctance Sensor	10-7003
Relay	99-REL-0001
Strain Relief (Power Input)	99-CON-0011
Strain Relief (Control)	99-CON-0012

EAGLE 2

Dual Channel Critical Speed Switch
MODEL 11-7000

TYPICAL BELT STARTER

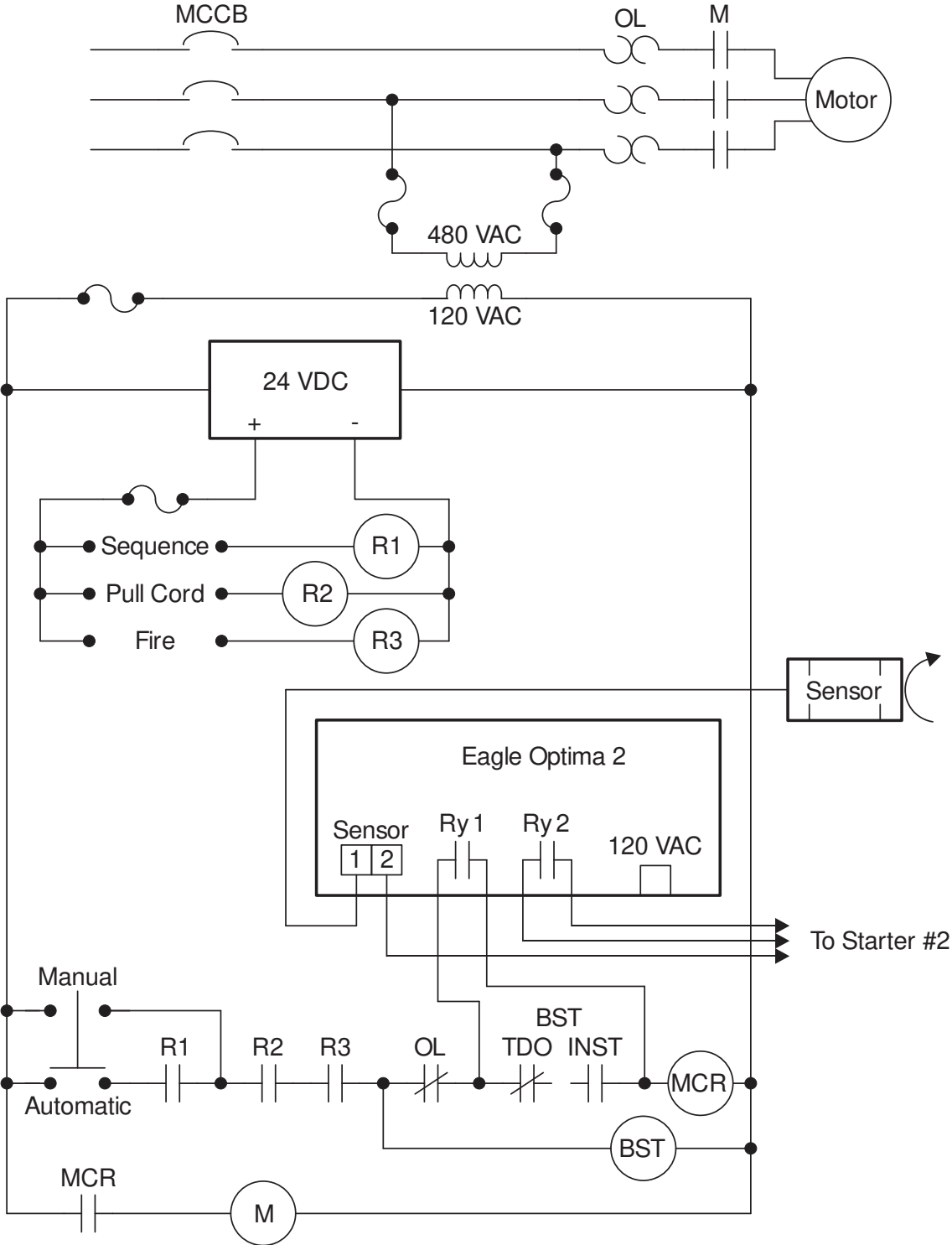

VR SENSOR

Variable Reluctance Type

MODEL 10-7003

INSTALLATION

1. Select the roller or shaft to be monitored. If a roller is to be monitored, be sure it is always contacting the belt.
2. Affix a target on the roller or shaft. Target should be a piece of key stock, 1/4-20 Hex Nut, etc. (Figure 1) Dents and notches are not recommended as targets.
3. Mount sensor firmly with hose clamps or U-bolts to prevent it from moving or working loose. Tape is **NOT** recommended as a fastener.
4. Before tightening, place sensor close enough to the target(s) to produce a strong, steady blinking on the sensor-head LED. The LED should blink in direct proportion to the roller speed. Effective distance between sensor and target(s) is approximately .25 inch to .75 inch depending on target mass and roller speed.

Figure 1

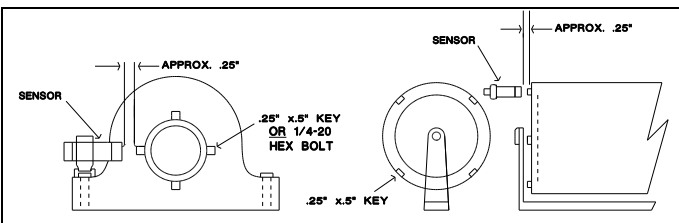

DIMENSIONS

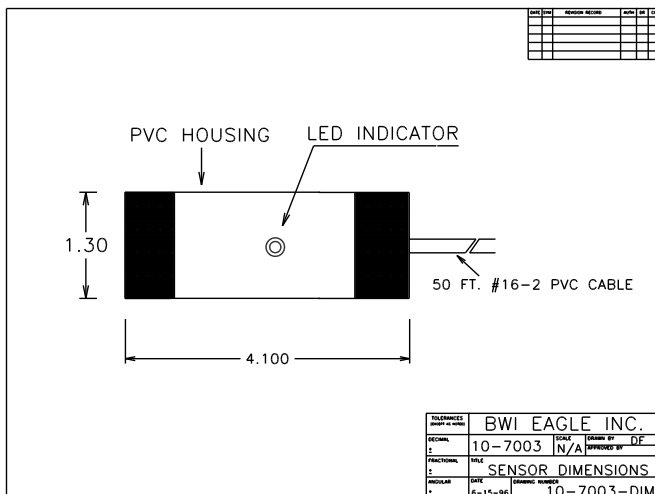

SPECIFICATIONS

Dimensions	4 in. x 1.3 in. O.D.
Sensor Type	Variable Reluctance Failsafe Output
Sensor Power Requirement	Current limited 12 VDC from Control Unit
Sensor Cable	Unshielded Twisted Pair 16/2
Distance	Sensor to control unit - 2 Miles MAX
Minimum Sensing Speed	60 RPM

DOCUMENT REV. DATE: 8/21/19 / PRODUCT REV. 0



105 Bonnie Drive
Butler, PA 16002
(724) 283-4681
Fax (724) 283-5939
www.bwieagle.com