



105 Bonnie Drive
Butler, PA 16002
724-283-4681
724-283-5939 (fax)
www.bwieagle.com

PRODUCT INFORMATION BULLETIN

AIR-EAGLE® SR 2.4 GHz RF Receiver MODEL 38-20100-AC

DESCRIPTION

The AIR-EAGLE SR is an RF system designed for short to medium range wireless remote control of electrical apparatus in a variety of industrial applications. Systems can consist of any number of receivers and handheld or contact input transmitters working together. This receiver is equipped with single relay can switch 5 amps @ 250VAC or 30VDC. The relay is user programmable for momentary, toggle/latching or latching operation and can be directly interfaced with the customer's equipment or P.L.C. Eight user selectable frequencies allow multiple systems to be used in the same area. Capable of receiving remote signals transmitted from up to 600 feet away, the Air-Eagle SR Receiver utilizes spread-spectrum technology and provides the utmost security and reliability even in the noisiest RF environments.

APPROVALS

United States (FCC)	MCQ-XBEE3
Canada (IC)	1846A-XBEE3
Europe (CE)	ETSI

INSTALLATION

DISCONNECT AC Power from all equipment before installation.

1. Mount the AIR-EAGLE SR RECEIVER in a convenient location.
2. Install wiring to terminal strip.
3. Attach supplied rubber duck antenna to TNC connector on the top side of the unit.
4. Connect supplied power input cable to your external power source.

TERMINAL STRIP WIRING

TER 3 INPUT		TER 2 RELAY OUTPUT		TER 1 AC/DC POWER INPUT	
1	Not Used	1	N/O	1	100-250 VAC
2	Not Used	2	C (common)	2	100-250 VAC
		3	N/C	3	Ground



Dimensions (with mounting plate)
7.07L x 3.57W x 1.62H

CONTROLS AND INDICATORS

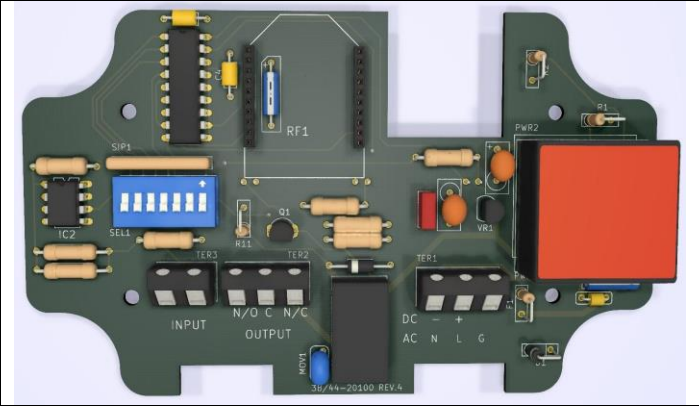

Power – LED1	Illuminates green when unit is powered
TX – LED2	Not used on this model
Relay – LED3	Illuminates green when relay is energized
RF1	RF module that sends data to the remote receiver
SEL1	Seven dip switches for selecting options & network frequency
TER3	Dry contact input
TER2	Relay output
TER1	Power Input

AIR-EAGLE® SR

2.4 GHz RF Receiver

MODEL 38-20100-AC

RELAY & FREQUENCY SET-UP

The unit is shipped from the factory with SEL1 switches in the open positions. The relay will operate as maintained momentary and unit is receiving commands on frequency one. If you wish to change these default settings, follow the instructions on the table below.

- 1) Remove power from unit
- 2) Remove top cover.
- 3) Select desired relay operation and/or network frequency using table below.
- 4) Reattach cover and apply power.
- 5) Programming is now complete.

RELAY CONFIGURATION

	Relay Operation	SW1	SW2
SEL1 (SW1-2)	Momentary <i>(default)</i>	OPEN	OPEN
	Toggle/Latch	CLOSED	OPEN
	Latching	OPEN	CLOSED

OPTIONS

SW3	Vibrating Feedback Off	Vibrating Feedback On
SW4**	Repeater Function Off <i>(default)</i>	Repeater Function On

Maintained Momentary – Relay mimics button or input – when depressed or closed, relay will be energized; when released, relay de-energizes

Toggle/Latch – Relay changes (and holds) its state each time the corresponding button or input is depressed or closed.

Latching – Relay requires two buttons or inputs for operation – momentary press of 1st button energizes relay; momentary press of 2nd button de-energizes relay

** Enable SW4 Repeater Function in ONLY one Receiver per System

FREQUENCY SET-UP

	Network Frequency	SW5	SW6	SW7
SEL1 (SW5-7)	1 <i>(default)</i>	OPEN	OPEN	OPEN
	2	CLOSED	OPEN	OPEN
	3	OPEN	CLOSED	OPEN
	4	CLOSED	CLOSED	OPEN
	5	OPEN	OPEN	CLOSED
	6	CLOSED	OPEN	CLOSED
	7	OPEN	CLOSED	CLOSED
	8	CLOSED	CLOSED	CLOSED

SPECIFICATIONS

AC Input	100-250 VAC, 5 W, 50/60 Hz
Relay Contact	SPDT 5 amp @ 250VAC or 30VDC
Fuse Protected	1 amp
Receiver Frequency	2.4 GHz Spread Spectrum
Receiver Range	Up to 600 feet
<small>Note: Range figures are estimates, based on free-air terrain with limited sources of interference. Actual range will vary based on transmitting power, orientation of transmitter and receiver, height of transmitting antenna, height of receiving antenna, weather conditions, interference sources in the area, and terrain between receiver and transmitter, including, but not limited to, indoor and outdoor structures such as walls, metal objects, trees, buildings, hills, and mountains.</small>	
Receiver Channels	Eight independent network frequencies
Operating Temperature	-40° F to +185° F
Enclosure	Polycarbonate NEMA 4, IP66
Weight	Approx 2 lbs.

DIMENSIONS

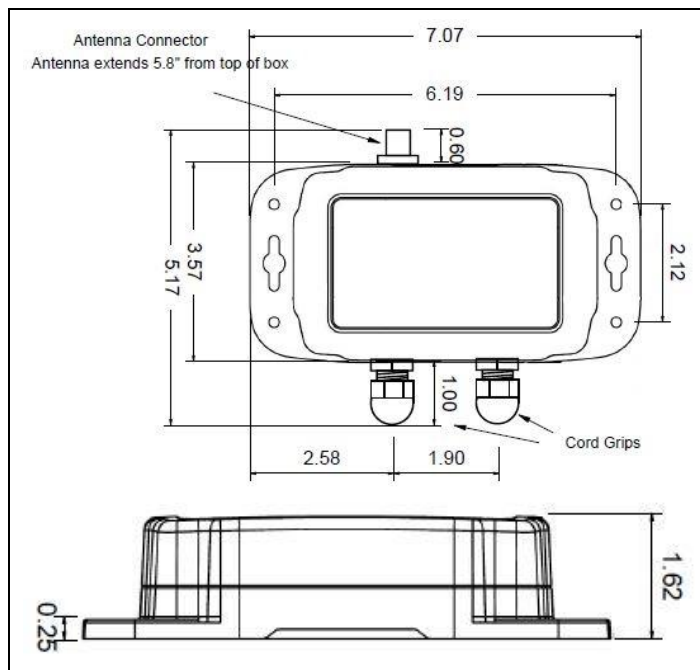

AIR-EAGLE® SR

2.4 GHz RF Receiver

MODEL 38-20100-AC

ACCESSORIES

Standard Antenna (Included):	
2.4GHz TNC "Rubber Duck" Antenna	49-1201
Mobile/Base Antennas – Used to help achieve max range in both non line of sight and line of sight applications. - Contact BWI Eagle for recommendations	
2.4GHz Thru-Hole Mount Mobile Antenna	49-2201
2.4GHz Magnet Mount Mobile Antenna	49-2202
2.4GHz Omni Directional Base Antenna	49-3201
2.4GHz Yagi Directional Base Antenna	49-3202
High Quality Coax Cables – Used to connect external high gain antennas to control unit	
Flex Coax Cable w/Connectors – Available in 5', 15', 25', 30', 40', 60', 80', 100' Lengths	49-4000-XX (XX = # of Feet)
Bulkhead Extensions – Used to provide an external antenna connection when mounting control unit inside another enclosure	
TNC Male to TNC Bulkhead Cable Assembly - Available in 2', 4', 7' Lengths	49-5004-X-ISO (X = # of Feet)

LIMITED WARRANTY STATEMENT

BWI Eagle Inc. warrants the Air-Eagle Remote Control System, if properly used and installed, will be free from defects in material and workmanship for a period of 1 year after date of purchase. Said warranty to include the repair or replacement of defective equipment. This warranty does not cover damage due to external causes, including accident, problems with electrical power, usage not in accordance with product instructions, misuse, neglect, alteration, repair, improper installation, or improper testing. This limited warranty, and any implied warranties that may exist under state law, apply only to the original purchaser of the equipment, and last only for as long as such purchaser continues to own the equipment. This warranty replaces all other warranties, express or implied including, but not limited to, the implied warranties or merchantability and fitness for a particular purpose. BWI Eagle makes no express warranties beyond those stated here. BWI disclaims without limitation, implied warranties of merchantability and fitness for a particular purpose. Some jurisdictions do not allow the exclusion of implied warranties so this limitation may not apply to you. To obtain warranty service, contact BWI Eagle for a return material authorization. When returning equipment to BWI Eagle, the customer assumes the risk of damage or loss during shipping and is responsible for the shipping costs incurred.

DOCUMENT DATE: 07/21/2021 / PRODUCT REV. 4



105 Bonnie Drive
Butler, PA 16002
(724) 283-4681
Fax (724) 283-5939
www.bwieagle.com



105 Bonnie Drive
Butler, PA 16002
724-283-4681
724-283-5939 (fax)
www.bwieagle.com

INPUT/OUTPUT WIRING

1-Input Transmitter / 1-Relay Receiver

Dry Contact Input Wiring - Standard

Standard wiring of a dry contact input transmitter

Shorting together the contacts of the respective channel will cause it to transmit. This can be done with any type of manual or automatic switch.

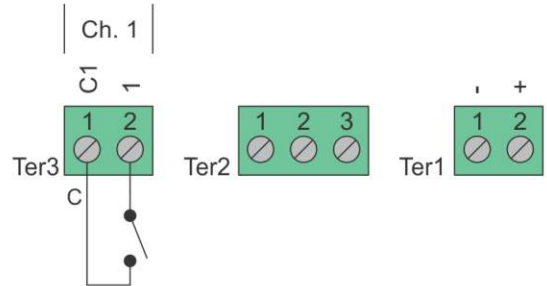

Relay Output Wiring

Receiver outputs are dry relay contacts, like an SPDT switch. When the relay is in a de-energized state, the N/C (normally closed) contact is connected to C (common). When the relay is energized the N/O (normally open) contact is connected to C (common).

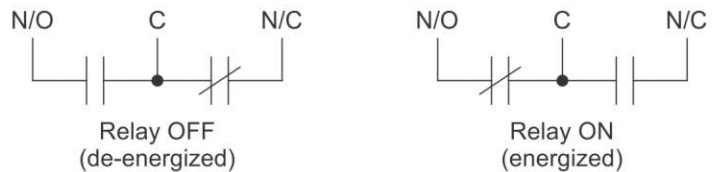

Relay Output Wiring - Normally Open Application with Externally Supplied Voltage

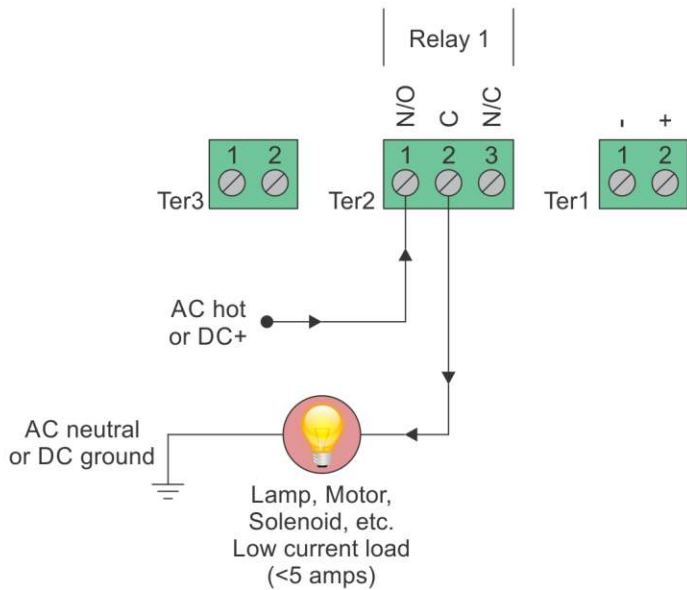

Internal Relay - Loads Less Than 5 Amps

Loads up to 5 Amps may be wired directly to the internal relays. Wiring to the N/O contact will cause the load to turn on when the relay is energized (the load is on when the relay is on). Wiring to the N/C contact will cause the load to turn on when the relay is de-energized (the load is on when the relay is off). AC or DC voltages can be switched through the relay.

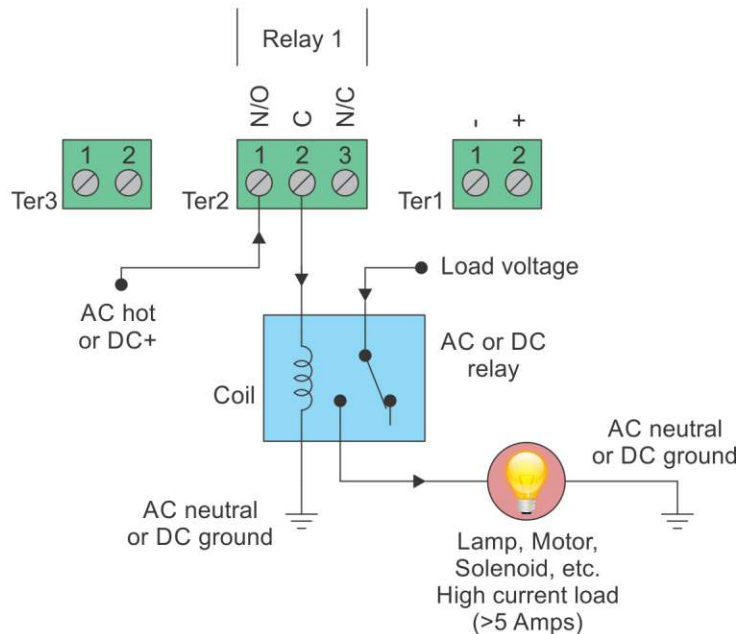

External Relay - Loads Over 5 Amps

Loads over 5 Amps must use an external high current relay. Diagram shows how to turn on the relay using the lower current internal relay of the receiver. AC or DC voltages can be switched through the relay. Note: A protection diode for DC coils or an MOV for AC coils is recommended to reduce inductive EMI noise.