



105 Bonnie Drive  
Butler, PA 16002  
724-283-4681  
724-283-5939 (fax)  
www.bwieagle.com

# PRODUCT INFORMATION BULLETIN

## AIR-EAGLE® XLT 900 MHz RF Transmitter MODEL 441-10100-DCI-AC

### DESCRIPTION

The AIR-EAGLE XLT TX is an R.F. transmitter capable of sending a single 5-24VDC input command to an Air-Eagle XLT Receiver located up to 2500 feet away (longer ranges can be achieved using external antennas). Any number of transmitters and receivers can be combined to create a medium range radio frequency system that operates hazardous or hard-to-reach electrical apparatus from safe, convenient locations. Eight user-selectable frequencies allow multiple systems to operate simultaneously in the same area without interference.

### APPROVALS

United States (FCC)	MCQ-XB900HP
Canada (IC)	1846A-XB900HP

### INSTALLATION

DISCONNECT AC Power from all equipment before installation.

1. Mount the AIR-EAGLE XLT TRANSMITTER in a convenient location.
2. Install wiring to terminal strip
3. Make desired channel code, repeater mode and frequency selections using instructions on page 2.
4. Install antenna onto connector located on the top on the enclosure.
5. Connect supplied power input cable to your external power source.

### TERMINAL STRIP WIRING

TER 3 VOLTAGE INPUT		TER 2 RELAY OUTPUT		TER 1 AC/DC POWER INPUT	
1	(-) 5-24VDC	1	Not Used	1	100-250 VAC
2	(+) 5-24VDC	2	Not Used	2	100-250 VAC
		3	Not Used	3	Ground

### GENERAL OPERATION

When 5-24VDC appears on the input the unit transmits to energize relay 1 (or another relay as selected by the channel code transmitted) in any receiver within transmit range. The signal transmits continuously as long 5-24VDC is present and ceases when 5-24VDC is removed.



Dimensions (with mounting plate) 7.07L x 3.57W x 1.62H

### CONTROLS AND INDICATORS

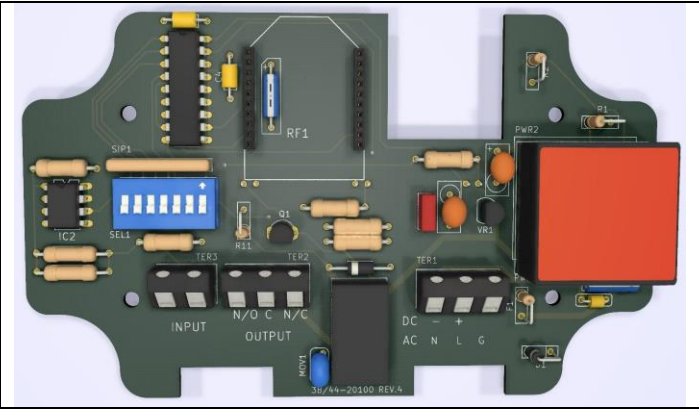

Power – LED1	Illuminates green when unit is powered
TX – LED2	Illuminates red when unit is transmitting
Relay – LED3	Not used on this model
RF1	RF module that sends data to the remote receiver
SEL1	Seven dip switches for selecting options and network frequency
TER3	Voltage input
TER2	Relay output
TER1	Power Input

# AIR-EAGLE® XLT

900 MHz RF Transmitter

**MODEL 441-10100-DCI-AC**

## CHANNEL CODE, REPEATER MODE & FREQUENCY SET-UP

The unit is shipped from the factory with all SEL1 switches in the open positions. By default, it is transmitting Channel #1 code, the command transmitted will not be repeated by the receivers, and it is operating on Frequency #1. If you wish to transmit a different channel code, set the unit to transmit a repeating packet, and/or change the frequency, follow the instructions on the table below.

- 1) Remove power from unit
- 2) Remove top cover.
- 3) Select desired channel code and/or frequency using table below.
- 4) Reattach cover and apply power.
- 5) Programming is now complete.

### CHANNEL SELECTION SET-UP

SEL 1 (SW1-3)	Channel Code To Be Transmitted	SW1	SW2	SW3
	1 (default)	OPEN	OPEN	OPEN
	2	CLOSED	OPEN	OPEN
	3	OPEN	CLOSED	OPEN
	4	CLOSED	CLOSED	OPEN
	5	OPEN	OPEN	CLOSED
	6	CLOSED	OPEN	CLOSED
	7	OPEN	CLOSED	CLOSED
	8	CLOSED	CLOSED	CLOSED

### REPEATER MODE

SEL1 SWITCH NUMBER	OPEN	CLOSED
SW4	Repeater Mode OFF (default)	Repeater Mode ON

### FREQUENCY SET-UP

SEL 1 (SW5-7)	Network Frequency	SW5	SW6	SW7
	1 (default)	OPEN	OPEN	OPEN
	2	CLOSED	OPEN	OPEN
	3	OPEN	CLOSED	OPEN
	4	CLOSED	CLOSED	OPEN
	5	OPEN	OPEN	CLOSED
	6	CLOSED	OPEN	CLOSED
	7	OPEN	CLOSED	CLOSED
	8	CLOSED	CLOSED	CLOSED

## DIMENSIONS

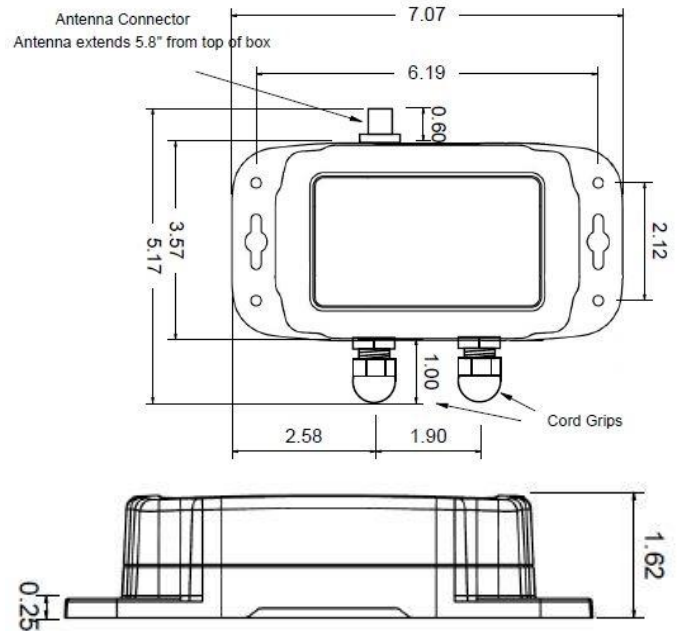

## SPECIFICATIONS

AC Input	100-250 VAC, 5 W, 50/60 Hz
Transmitter Frequency	900 MHz Spread Spectrum
RF Output Power	250 mW
Transmit Range	Up to 2500 Feet w/Standard Antenna
<p><small>Note: Max range figures are estimates, based on free-air terrain with limited sources of interference. Actual range will vary based on transmitting power, orientation of transmitter and receiver, height of transmitting antenna, height of receiving antenna, weather conditions, interference sources in the area, and terrain between receiver and transmitter, including, but not limited to, indoor and outdoor structures such as walls, metal objects, trees, buildings, hills, and mountains</small></p>	
Transmit Data	5-24VDC Input
RF Networks	Eight Independent Frequencies
Antenna Connection	TNC Female Connector
Operating Temperature	-40° F to +185° F
Enclosure	Polycarbonate NEMA 4, 12, 13 – IP66
Weight	Approx 2 lbs.

# AIR-EAGLE® XLT

900 MHz RF Transmitter

**MODEL 441-10100-DCI-AC**

## ACCESSORIES

Standard Antenna (Included):	
900MHz TNC "Rubber Duck" Antenna	49-1103
Mobile/Base Antennas – Used to help achieve max range in both non line of sight and line of sight applications. - Contact BWI Eagle for recommendations	
900MHz Thru-Hole Mount Mobile Antenna	49-2101
900MHz Magnet Mount Mobile Antenna	49-2102
900MHz Omni Directional Base Antenna	49-3101
900MHz Yagi Directional Base Antenna	49-3102
High Quality Coax Cables – Used to connect external high gain antennas to control unit	
Flex Coax Cable w/Connectors – Available in 5', 15', 25', 30', 40', 60', 80', 100' Lengths	49-4000-XX (XX = # of Feet)
Bulkhead Extensions – Used to provide an external antenna connection when mounting control unit inside another enclosure	
TNC Male to TNC Bulkhead Cable Assembly - Available in 2', 4', 7' Lengths	49-5004-X-ISO (X = # of Feet)

## LIMITED WARRANTY STATEMENT

BWI Eagle Inc. warrants the Air-Eagle Remote Control System, if properly used and installed, will be free from defects in material and workmanship for a period of **1 year** after date of purchase. Said warranty to include the repair or replacement of defective equipment. This warranty does not cover damage due to external causes, including accident, problems with electrical power, usage not in accordance with product instructions, misuse, neglect, alteration, repair, improper installation, or improper testing. This limited warranty, and any implied warranties that may exist under state law, apply only to the original purchaser of the equipment, and last only for as long as such purchaser continues to own the equipment. This warranty replaces all other warranties, express or implied including, but not limited to, the implied warranties or merchantability and fitness for a particular purpose. BWI Eagle makes no express warranties beyond those stated here. BWI disclaims without limitation, implied warranties of merchantability and fitness for a particular purpose. Some jurisdictions do not allow the exclusion of implied warranties so this limitation may not apply to you. To obtain warranty service, contact BWI Eagle for a return material authorization. When returning equipment to BWI Eagle, the customer assumes the risk of damage or loss during shipping and is responsible for the shipping costs incurred.

DOCUMENT DATE: 07/22/2021 / PRODUCT REV. 6



105 Bonnie Drive  
Butler, PA 16002  
(724) 283-4681  
Fax (724) 283-5939  
[www.bwieagle.com](http://www.bwieagle.com)