



105 Bonnie Drive
Butler, PA 16002
724-283-4681
724-283-5939 (fax)
www.bwieagle.com

PRODUCT INFORMATION BULLETIN

AIR-EAGLE® XLT 900 MHz RF Receiver MODEL 441-20100-X-AC

DESCRIPTION

The AIR-EAGLE XLT is an RF system designed for short to medium range wireless remote control of electrical apparatus in a variety of industrial applications. Systems can consist of any number of receivers and handheld or contact input transmitters working together. This receiver is equipped with single relay that can switch 5 amps @ 120VAC or 30VDC and can be directly interfaced with the customer's equipment or P.L.C. Eight user selectable frequencies allow multiple systems to be used in the same area. The Air-Eagle XLT can receive remote signals transmitted from up to 2500 feet away (with a handheld transmitter) or up to 2 miles away (with a stationary transmitter and external antennas).

MODEL INFORMATION

In this model the "-X" denotes that the user can select which transmitter input channel or button activates the relay – see CHANNEL CODE & FREQUENCY SET-UP on page 2.

APPROVALS

United States (FCC)	MCQ-XB900HP
Canada (IC)	1846A-XB900HP

INSTALLATION

DISCONNECT AC Power from all equipment before installation.

1. Mount the AIR-EAGLE XLT RECEIVER in a convenient location.
2. Install wiring to terminal strip.
3. Attach supplied rubber duck antenna to TNC connector on the top side of the unit.
4. Connect supplied power input cable to your external power source.

TERMINAL STRIP WIRING

TER 3 INPUT		TER 2 RELAY OUTPUT		TER 1 AC/DC POWER INPUT	
1	Not Used	1	N/O	1	100-250 VAC
2	Not Used	2	C (common)	2	100-250 VAC
		3	N/C	3	Ground



Dimensions (with mounting plate)
7.07L x 3.57W x 1.62H

CONTROLS AND INDICATORS

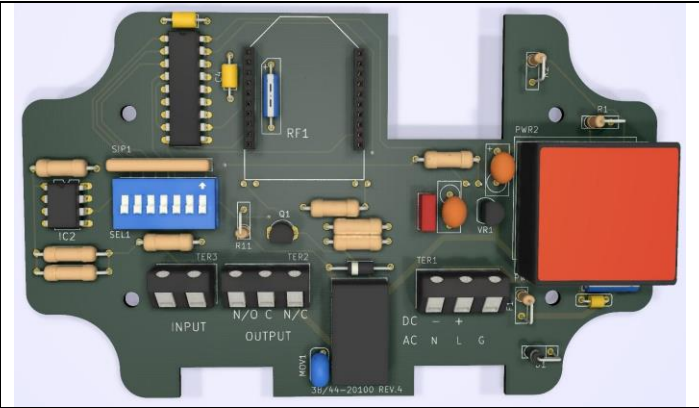

Power – LED1	Illuminates green when unit is powered
TX – LED2	Not used on this model
Relay – LED3	Illuminates green when relay is energized
RF1	RF module that sends data to the remote receiver
SEL1	Seven dip switches for selecting options & network frequency
TER3	Dry contact input
TER2	Relay output
TER1	Power Input

AIR-EAGLE® XLT

900 MHz RF Receiver

MODEL 441-20100-X-AC

CHANNEL CODE & FREQUENCY SET-UP

The unit is shipped from the factory with all SEL1 switches in the open positions. By default, it is receiving Channel #1 code and operating on Frequency #1. If you wish to receive a different channel code or and/or change the frequency, follow the instructions on the table below.

- 1) Remove power from unit
- 2) Remove top cover.
- 3) Select desired channel code and/or frequency using table below.
- 4) Reattach cover and apply power.
- 5) Programming is now complete.

CHANNEL SELECTION SET-UP

SEL1 (SW1-4)	Channel Code To Be Received	SW1	SW2	SW3	SW4
	1 (default)	OPEN	OPEN	OPEN	OPEN
	2	CLOSED	OPEN	OPEN	OPEN
	3	OPEN	CLOSED	OPEN	OPEN
	4	CLOSED	CLOSED	OPEN	OPEN
	5	OPEN	OPEN	CLOSED	OPEN
	6	CLOSED	OPEN	CLOSED	OPEN
	7	OPEN	CLOSED	CLOSED	OPEN
	8	CLOSED	CLOSED	CLOSED	OPEN
	9	OPEN	OPEN	OPEN	CLOSED
	10	CLOSED	OPEN	OPEN	CLOSED
	11	OPEN	CLOSED	OPEN	CLOSED
	12	CLOSED	CLOSED	OPEN	CLOSED
	13	OPEN	OPEN	CLOSED	CLOSED
	14	CLOSED	OPEN	CLOSED	CLOSED
	15	OPEN	CLOSED	CLOSED	CLOSED
	16	CLOSED	CLOSED	CLOSED	CLOSED

FREQUENCY SET-UP

SEL1 (SW5-7)	Network Frequency	SW5	SW6	SW7
	1 (default)	OPEN	OPEN	OPEN
	2	CLOSED	OPEN	OPEN
	3	OPEN	CLOSED	OPEN
	4	CLOSED	CLOSED	OPEN
	5	OPEN	OPEN	CLOSED
	6	CLOSED	OPEN	CLOSED
	7	OPEN	CLOSED	CLOSED
8	CLOSED	CLOSED	CLOSED	

SPECIFICATIONS

AC Input	100-250 VAC, 5 W, 50/60 Hz
Relay Contact	SPDT 5 amp @ 120VAC or 30VDC
Fuse Protected	1 amp
Receiver Frequency	900 MHz Spread Spectrum
Receiver Range	Up to 2500 Feet w/Standard Antenna
<small>Note: Max range figures are estimates, based on free-air terrain with limited sources of interference. Actual range will vary based on transmitting power, orientation of transmitter and receiver, height of transmitting antenna, height of receiving antenna, weather conditions, interference sources in the area, and terrain between receiver and transmitter, including, but not limited to, indoor and outdoor structures such as walls, metal objects, trees, buildings, hills, and mountains</small>	
RF Networks	Eight Independent Frequencies
Operating Temperature	-40° F to +185° F
Enclosure	Polycarbonate NEMA 4, 12, 13 – IP66
Weight	Approx 2 lbs.

DIMENSIONS

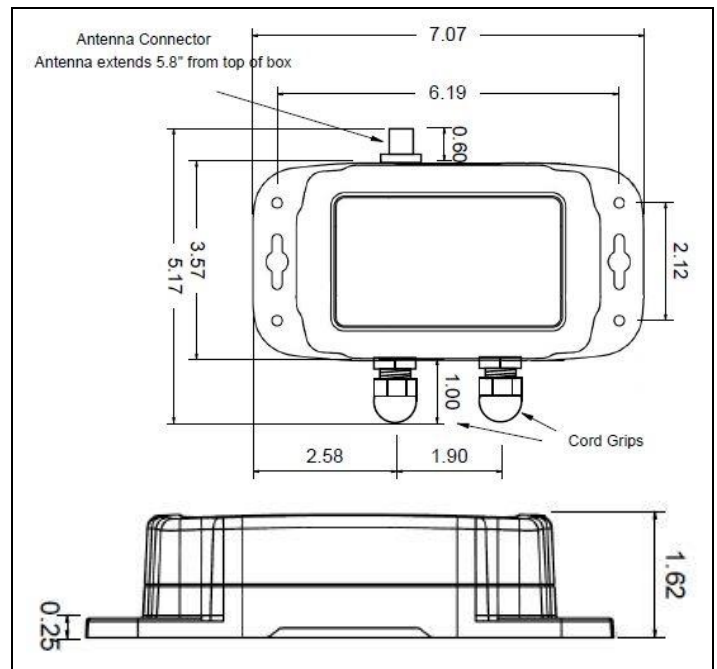

ACCESSORIES

Standard Antenna (Included):	
900MHz TNC "Rubber Duck" Antenna	49-1103
Mobile/Base Antennas – Used to help achieve max range in both non line of sight and line of sight applications. - Contact BWI Eagle for recommendations	
900MHz Thru-Hole Mount Mobile Antenna	49-2101
900MHz Magnet Mount Mobile Antenna	49-2102
900MHz Omni Directional Base Antenna	49-3101
900MHz Yagi Directional Base Antenna	49-3102
High Quality Coax Cables – Used to connect external high gain antennas to control unit	
Flex Coax Cable w/Connectors – Available in 5', 15', 25', 30', 40', 60', 80', 100' Lengths	49-4000-XX (XX = # of Feet)
Bulkhead Extensions – Used to provide an external antenna connection when mounting control unit inside another enclosure	
TNC Male to TNC Bulkhead Cable Assembly - Available in 2', 4', 7' Lengths	49-5004-X-ISO (X = # of Feet)

AIR-EAGLE® XLT

900 MHz RF Receiver

MODEL 441-20100-X-AC

LIMITED WARRANTY STATEMENT

BWI Eagle Inc. warrants the Air-Eagle Remote Control System, if properly used and installed, will be free from defects in material and workmanship for a period of 1 year after date of purchase. Said warranty to include the repair or replacement of defective equipment. This warranty does not cover damage due to external causes, including accident, problems with electrical power, usage not in accordance with product instructions, misuse, neglect, alteration, repair, improper installation, or improper testing. This limited warranty, and any implied warranties that may exist under state law, apply only to the original purchaser of the equipment, and last only for as long as such purchaser continues to own the equipment. This warranty replaces all other warranties, express or implied including, but not limited to, the implied warranties of merchantability and fitness for a particular purpose. BWI Eagle makes no express warranties beyond those stated here. BWI disclaims without limitation, implied warranties of merchantability and fitness for a particular purpose. Some jurisdictions do not allow the exclusion of implied warranties so this limitation may not apply to you. To obtain warranty service, contact BWI Eagle for a return material authorization. When returning equipment to BWI Eagle, the customer assumes the risk of damage or loss during shipping and is responsible for the shipping costs incurred.

DOCUMENT DATE: 07/22/2021 / PRODUCT REV. 5



105 Bonnie Drive
Butler, PA 16002
(724) 283-4681
Fax (724) 283-5939
www.bwieagle.com



105 Bonnie Drive
Butler, PA 16002
724-283-4681
724-283-5939 (fax)
www.bwieagle.com

INPUT/OUTPUT WIRING

1-Input Transmitter / 1-Relay Receiver

Dry Contact Input Wiring - Standard

Standard wiring of a dry contact input transmitter

Shorting together the contacts of the respective channel will cause it to transmit. This can be done with any type of manual or automatic switch.

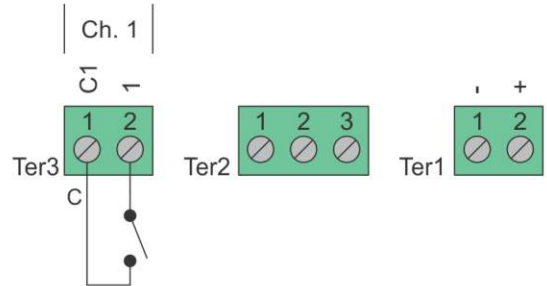

Relay Output Wiring

Receiver outputs are dry relay contacts, like an SPDT switch. When the relay is in a de-energized state, the N/C (normally closed) contact is connected to C (common). When the relay is energized the N/O (normally open) contact is connected to C (common).

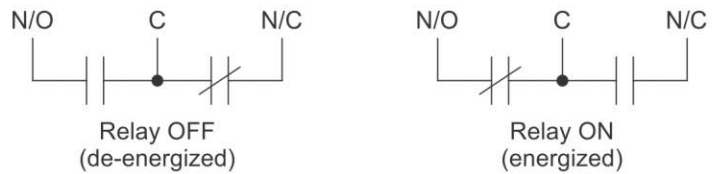

Relay Output Wiring - Normally Open Application with Externally Supplied Voltage

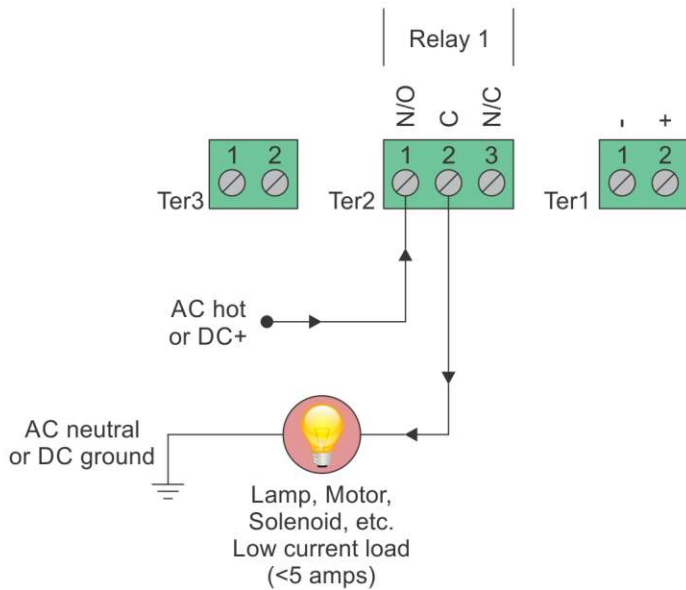

Internal Relay - Loads Less Than 5 Amps

Loads up to 5 Amps may be wired directly to the internal relays. Wiring to the N/O contact will cause the load to turn on when the relay is energized (the load is on when the relay is on). Wiring to the N/C contact will cause the load to turn on when the relay is de-energized (the load is on when the relay is off). AC or DC voltages can be switched through the relay.

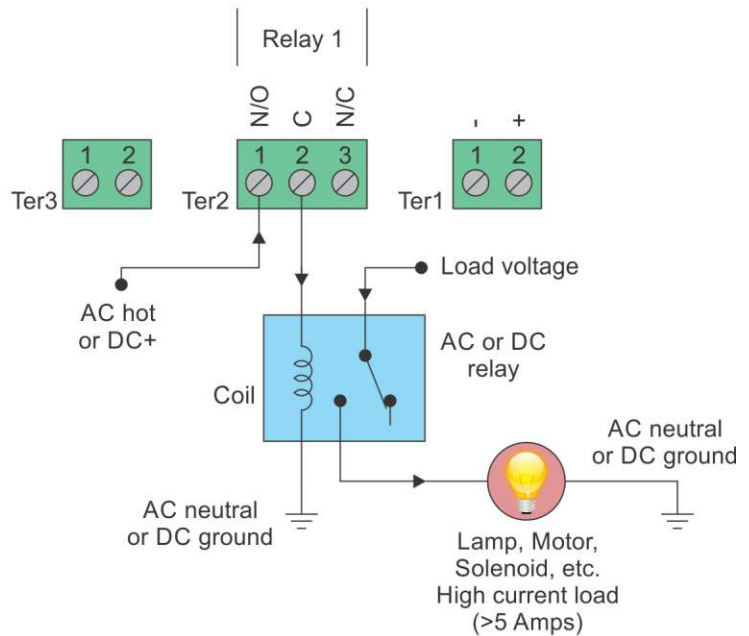

External Relay - Loads Over 5 Amps

Loads over 5 Amps must use an external high current relay. Diagram shows how to turn on the relay using the lower current internal relay of the receiver. AC or DC voltages can be switched through the relay. Note: A protection diode for DC coils or an MOV for AC coils is recommended to reduce inductive EMI noise.