

AIR-EAGLE XLT PLUS

461-1400-AC

900 MHz RF Transmitter



Document Date: 9/19/2023
Product Rev: 9

BWI Eagle, Inc.
105 Bonnie Dr.
Butler, PA 16002
724-283-4681
724-283-5939 (fax)
www.bwieagle.com
sales@bwieagle.com



WARRANTY STATEMENT

BWI Eagle Inc. warrants the Air-Eagle Remote Control System, if properly used and installed, will be free from defects in material and workmanship for a period of **1 year** after date of purchase. Said warranty to include the repair or replacement of defective equipment. This warranty does not cover damage due to external causes, including accident, problems with electrical power, usage not in accordance with product instructions, misuse, neglect, alteration, repair, improper installation, or improper testing. This limited warranty, and any implied warranties that may exist under state law, apply only to the original purchaser of the equipment, and last only for as long as such purchaser continues to own the equipment. This warranty replaces all other warranties, express or implied including, but not limited to, the implied warranties or merchantability and fitness for a particular purpose. BWI Eagle makes no express warranties beyond those stated here. BWI disclaims without limitation, implied warranties of merchantability and fitness for a particular purpose. Some jurisdictions do not allow the exclusion of implied warranties so this limitation may not apply to you. To obtain warranty service, contact BWI Eagle for a return material authorization. When returning equipment to BWI Eagle, the customer assumes the risk of damage or loss during shipping and is responsible for the shipping costs incurred.

SIGNAL RANGE

Max range statements are estimates based on a clear line of sight with few interferences. Actual range will vary based on transmitting power, orientation of transmitter and receiver, height of transmitting and receiving antennas, weather conditions, electronic interference, terrain, and physical obstacles, including but not limited to; walls, building structures, trees (foliage), metal objects, and landscape (hills, mountains).



WIRELESS STOP, ASTOP, and E-STOP SYSTEMS

Wireless E-STOP systems should never be considered a primary life-saving device. At least one hard-wired switch must be available in the event the wireless system is not operational. Failure to comply may result in serious injury or death to personnel and damage to equipment.

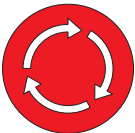

Wireless STOP and ASTOP transmitters are not failsafe emergency stop controls. They are NOT to be used as a life-saving device. They are designed for wireless control of equipment or vehicle remote operation. Failure to use as intended may result in serious injury or death to personnel and damage to equipment.



461-1400-AC



INTRODUCTION

The Air-Eagle XLT Plus is an RF system designed for long range wireless remote control of electrical apparatus in a variety of industrial applications. Systems can consist of any number of receivers and handheld or stationary transmitters working together to create a long range radio frequency system that operates hazardous or hard-to-reach equipment from safe, convenient locations.

Eight user selectable frequencies allow multiple systems to be used in the same area without interference.

This transmitter is equipped to send four independent dry-contact input commands to an Air-Eagle XLT Plus receiver located up to 5000 feet away. Longer ranges can be achieved with external antennas (See ACCESSORIES section). The Air-Eagle XLT Plus transmitter utilizes spread-spectrum technology and provides the utmost in security and reliability.

INSTALLATION

1. **DISCONNECT** power from all equipment before proceeding with installation.
2. Mount the transmitter in a convenient location.
3. Install input control wiring to the terminal strip. (See TERMINAL STRIP WIRING section.)
4. Attach rubber duck antenna or coax from external antenna to connector on side of enclosure.
5. Connect supplied power input cable to external power source.

GENERAL OPERATION

A closure on any input transmits its channel command to activate the corresponding relay in the remote receiver. The transmission continues as long as the input is closed and ceases when the input opens.

461-1400-AC

TERMINAL STRIP WIRING

Terminal 1	CH1 Dry Contact Input (Common)
Terminal 2	CH1 Dry Contact Input
Terminal 3	CH2 Dry Contact Input (Common)
Terminal 4	CH2 Dry Contact Input
Terminal 5	CH3 Dry Contact Input (Common)
Terminal 6	CH3 Dry Contact Input
Terminal 7	CH4 Dry Contact Input (Common)
Terminal 8	CH4 Dry Contact Input
Terminal 9	100-250 VAC (N) Input
Terminal 10	100-250 VAC (H) Input

APPROVALS

United States (FCC)	MCQ-XBPSX
Canada (IC)	1846A-XBPSX
Australia	RCM
Brazil	ANATEL: 05774-16-01209

461-1400-AC

FREQUENCY & DIGITAL ADDRESS SET-UP

The unit is shipped from the factory with all SEL1 and SEL2 switches in the open positions. It is operating on Frequency 1 and Digital Address 1. To change default settings, follow the instructions below:

*Note – only change the digital address if using with a digitally addressable receiver. Otherwise, the digital address must be kept at the default of Digital Address 1.

1. ***IMPORTANT***
Disconnect power from unit.
2. Remove top cover.
3. Select desired frequency and/or digital address using the table.
4. Reattach cover.
5. Reconnect power to unit.
6. Programming is complete.

FREQUENCY SETUP (SEL1)				
NETWORK FREQUENCY	SW1	SW2	SW3	
1 (default)	OPEN	OPEN	OPEN	
2	CLOSED	OPEN	OPEN	
3	OPEN	CLOSED	OPEN	
4	CLOSED	CLOSED	OPEN	
5	OPEN	OPEN	CLOSED	
6	CLOSED	OPEN	CLOSED	
7	OPEN	CLOSED	CLOSED	
8	CLOSED	CLOSED	CLOSED	
Note - SEL1 SW4 not used on this model. Leave in OPEN position				
DIGITAL ADDRESS SETUP (SEL2)				
DIGITAL ADDRESS	SW1	SW2	SW3	SW4
1 (default)	OPEN	OPEN	OPEN	OPEN
2	CLOSED	OPEN	OPEN	OPEN
3	OPEN	CLOSED	OPEN	OPEN
4	CLOSED	CLOSED	OPEN	OPEN
5	OPEN	OPEN	CLOSED	OPEN
6	CLOSED	OPEN	CLOSED	OPEN
7	OPEN	CLOSED	CLOSED	OPEN
8	CLOSED	CLOSED	CLOSED	OPEN
9	OPEN	OPEN	OPEN	CLOSED
10	CLOSED	OPEN	OPEN	CLOSED
11	OPEN	CLOSED	OPEN	CLOSED
12	CLOSED	CLOSED	OPEN	CLOSED
13	OPEN	OPEN	CLOSED	CLOSED
14	CLOSED	OPEN	CLOSED	CLOSED
15	OPEN	CLOSED	CLOSED	CLOSED
16	CLOSED	CLOSED	CLOSED	CLOSED
Note - SEL2 SW5-7 not used on this model. Leave in OPEN position				

461-1400-AC

CONTROLS & INDICATORS

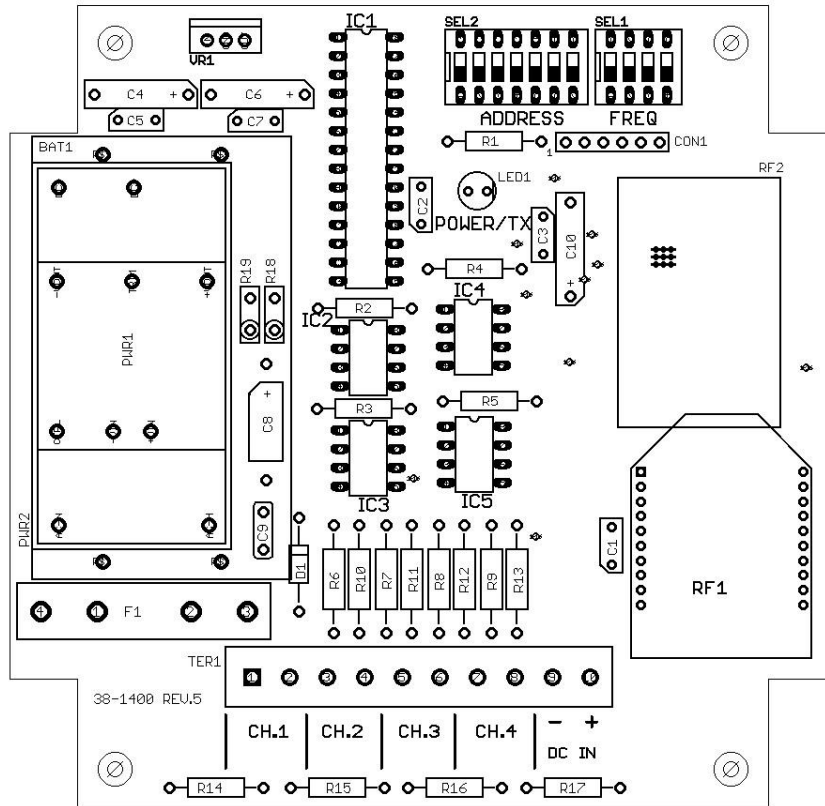

POWER/TX LED1	Dual color LED illuminates red while unit is booting up, changes to green when boot-up is successful and unit is ready to operate. If this LED fails to turn green, power unit off for 15-20 seconds, then reapply power.
Input Channels 1-4	Transmits individual RF codes to the receiver.
SEL1	Dip switch bank for frequency selection.
SEL2	Dip switch bank for digital address selection.
RF2	RF module that transmits data.

461-1400-AC

SPECIFICATIONS

Power Supply	100-250 VAC, 5 W, 50/60 Hz
Fuse Protected	2 amp
Transmit Data	Four Independent Dry Contact Inputs
Frequency	902-928 MHz Spread Spectrum
RF Output Power	1 Watt
Range	Up to 1 Mile (Up to 10 miles with external antenna - see accessories)
RF Networks	Eight Independent Network Frequencies
Operating Temperature	-40° F to +185° F
Enclosure	Polycarbonate, IP66 (NEMA 4)
<p>*Note: Max range statements are estimates based on a clear line of sight with few interferences. Actual range will vary based on transmitting power, orientation of transmitter and receiver, height of transmitting and receiving antennas, weather conditions, electronic interference, terrain, and physical obstacles, including but not limited to; walls, building structures, trees (foliage), metal objects, and landscape (hills, mountains).</p>	

ACCESSORIES

STANDARD ANTENNA (INCLUDED)	
900MHz TNC Portable "Rubber Duck" Antenna	49-1103
MOBILE/BASE ANTENNAS (OPTIONAL) Used to help achieve max range in non-line-of-sight and line-of-sight applications. Contact BWI Eagle for recommendations.	
900MHz Thru-Hole/Bracket Mount Mobile Antenna	49-2101
900MHz Magnet Mount Mobile Antenna	49-2102
900MHz Omni Directional Base Antenna	49-3101
900MHz Yagi Directional Base Antenna	49-3102
HIGH QUALITY COAX CABLE Used to connect external antennas to control unit.	
Flex Coax Cable w/Connectors (Available in 5', 15', 25', 30', 40', 60', 80', and 100' lengths)	49-4000-XX (XX = length in feet)
BULKHEAD EXTENSION Used to provide an external antenna connection when mounting control unit inside another enclosure.	
TNC Male to TNC Bulkhead Cable Assembly (Available in 2', 4', and 7' lengths)	49-5004-X-ISO (X = length in feet)

461-1400-AC

DIMENSIONS

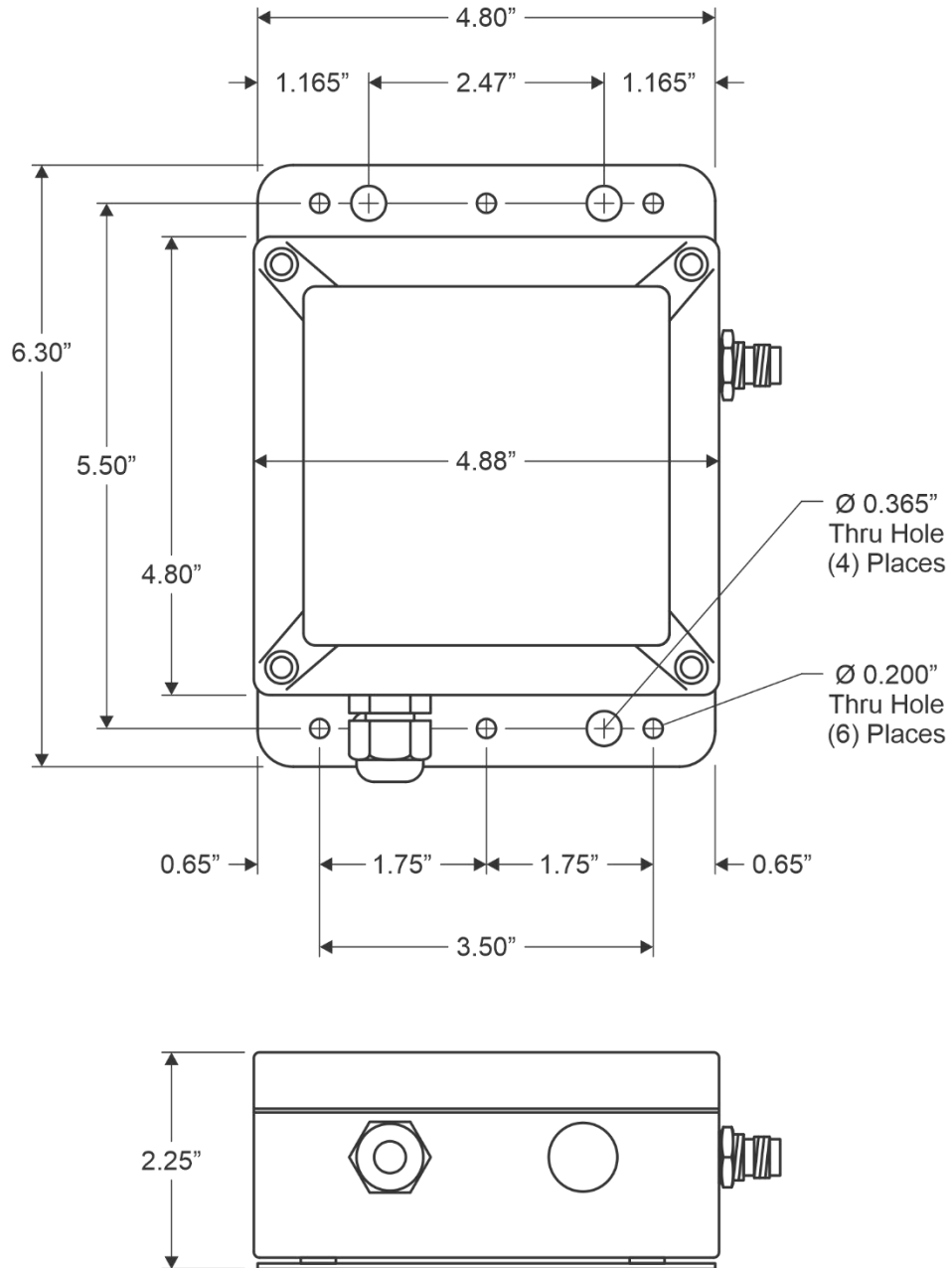



105 Bonnie Drive
Butler, PA 16002
724-283-4681
724-283-5939 (fax)
www.bwieagle.com

DRY CONTACT INPUT WIRING 4-Input Transmitter

Standard wiring of a dry contact input transmitter

Shorting together the contacts of the respective channel will cause it to transmit. This can be done with any type of manual or automatic switch.

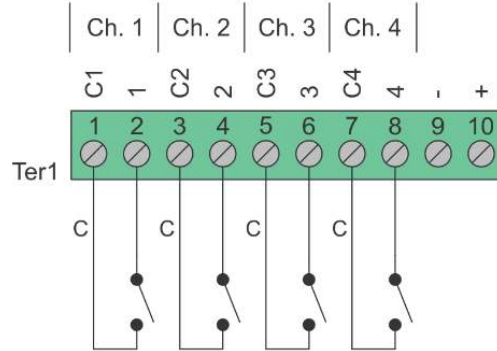

Standard Wiring for Common Ground Applications

Because each channel shares a common (C) terminal, inputs can be wired as shown to allow for fewer conductors to be run to the transmitter.

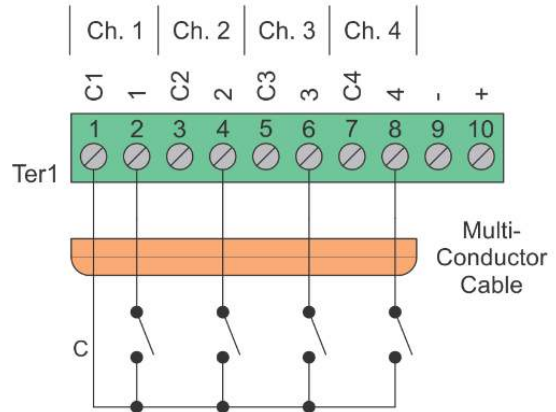

SPDT Switches

The common (C) terminal of the switch only needs to be connected to one of the channels ground terminal. In this configuration two channels would be transmitting all the time. A switch with a center "off" position would allow transmitting to stop. In this example channels 2 and 4 are transmitting.

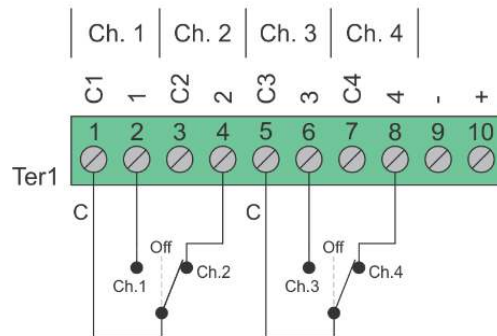

Wiring configurations shown here are examples. The wiring for your application may differ.
Call BWI Eagle for assistance or consult an electrician.