

AIR-EAGLE XLT PLUS 465P-8D-ESTOP-AC 900 MHz RF Receiver



Document Date: 09/20/2023
Product Rev: 3

BWI Eagle, Inc.
105 Bonnie Dr.
Butler, PA 16002
724-283-4681
724-283-5939 (fax)
www.bwieagle.com
sales@bwieagle.com



465P-8D-ESTOP-AC

WARRANTY STATEMENT

BWI Eagle Inc. warrants the Air-Eagle Remote Control System, if properly used and installed, will be free from defects in material and workmanship for a period of **1 year** after date of purchase. Said warranty to include the repair or replacement of defective equipment. This warranty does not cover damage due to external causes, including accident, problems with electrical power, usage not in accordance with product instructions, misuse, neglect, alteration, repair, improper installation, or improper testing. This limited warranty, and any implied warranties that may exist under state law, apply only to the original purchaser of the equipment, and last only for as long as such purchaser continues to own the equipment. This warranty replaces all other warranties, express or implied including, but not limited to, the implied warranties or merchantability and fitness for a particular purpose. BWI Eagle makes no express warranties beyond those stated here. BWI disclaims without limitation, implied warranties of merchantability and fitness for a particular purpose. Some jurisdictions do not allow the exclusion of implied warranties so this limitation may not apply to you. To obtain warranty service, contact BWI Eagle for a return material authorization. When returning equipment to BWI Eagle, the customer assumes the risk of damage or loss during shipping and is responsible for the shipping costs incurred.

SIGNAL RANGE

Max range statements are estimates based on a clear line of sight with few interferences. Actual range will vary based on transmitting power, orientation of transmitter and receiver, height of transmitting and receiving antennas, weather conditions, electronic interference, terrain, and physical obstacles, including but not limited to; walls, building structures, trees (foliage), metal objects, and landscape (hills, mountains).



WIRELESS STOP, ASTOP, and E-STOP SYSTEMS

Wireless E-STOP systems should never be considered a primary life-saving device. At least one hard-wired switch must be available in the event the wireless system is not operational. Failure to comply may result in serious injury or death to personnel and damage to equipment.

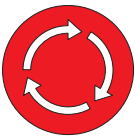

Wireless STOP and ASTOP transmitters are not failsafe emergency stop controls. They are NOT to be used as a life-saving device. They are designed for wireless control of equipment or vehicle remote operation. Failure to use as intended may result in serious injury or death to personnel and damage to equipment.



465P-8D-ESTOP-AC

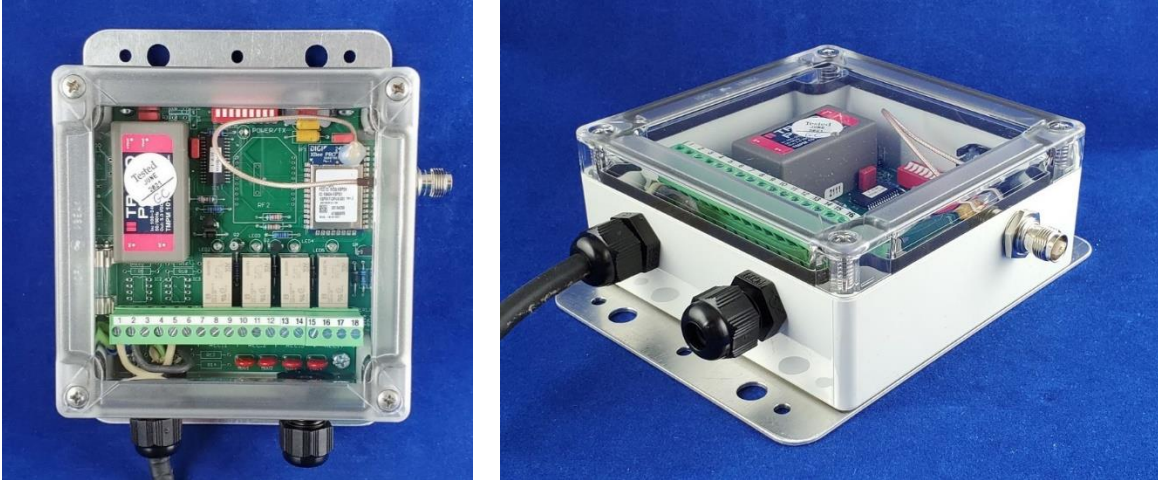

INTRODUCTION

The Air-Eagle XLT Plus is an RF system designed for long range wireless remote control of electrical apparatus in a variety of industrial applications. Systems can consist of any number of receivers and handheld or stationary transmitters working together to create a long range radio frequency system that operates hazardous or hard-to-reach equipment from safe, convenient locations.

Eight user selectable frequencies allow multiple systems to be used in the same area without interference.

This receiver is equipped with four independent relays that can switch 5 amps @ 120VAC or 30VDC. The relays are user programmable for momentary or toggle/latching operation and can be directly interfaced with the customer's equipment or P.L.C. It is capable of receiving remote signals from an Air-Eagle XLT Plus transmitter up to 5000 feet away. Longer ranges can be achieved with external antennas (See ACCESSORIES section). The Air-Eagle XLT Plus receiver utilizes spread-spectrum technology and provides the utmost in security and reliability.

This receiver is designed to work with a linking transmitter for failsafe operation. The transmitter is programmed to send a periodic heartbeat signal that continuously monitors the connection between the transmitter and receiver by keeping one or more relays in the receiver energized and the system running. The linked relays de-energize after a specified timeout period of link-loss and immediately upon activation of an E-stop button

INSTALLATION

1. **DISCONNECT** power from all equipment before proceeding with installation.
2. Mount the receiver in a convenient location.
3. Install relay control wiring to the terminal strip.
4. Attach rubber duck antenna or coax from external antenna to connector on side of enclosure.
5. Connect supplied power input cable to external power source.

465P-8D-ESTOP-AC

TERMINAL STRIP WIRING

Terminal 1	100-250 VAC Power Input	
Terminal 2	100-250 VAC Power Input	
Terminal 3	CH1 Dry Contact Input (Common)	Not used on this model
Terminal 4	CH1 Dry Contact Input	
Terminal 5	CH2 Dry Contact Input (Common)	
Terminal 6	CH2 Dry Contact Input	
Terminal 7	N/O Relay 1	
Terminal 8	C Relay 1	
Terminal 9	N/C Relay 1	
Terminal 10	N/O Relay 2	
Terminal 11	C Relay 2	
Terminal 12	N/C Relay 2	
Terminal 13	N/O Relay 3	
Terminal 14	C Relay 3	
Terminal 15	N/C Relay 3	
Terminal 16	N/O Relay 4	
Terminal 17	C Relay 4	
Terminal 18	N/C Relay 4	

APPROVALS

United States (FCC)	MCQ-XBPSX
Canada (IC)	1846A-XBPSX
Australia	RCM
Brazil	ANATEL: 05774-16-01209

465P-8D-ESTOP-AC

RELAY ASSIGNMENT & MODES

SPLIT RELAYS		
TRANSMITTER UNIT #	STOP	LOGIN
1	Relay 1	Relay 3
2	Relay 2	Relay 4

Split Relays:

The STOP relays turn ON at power up. When the STOP button is pressed, the STOP relay for the corresponding Unit # turns OFF. After the STOP button is released, the transmitter must be powered OFF to reset. Once reset, powering ON the transmitter will cause the STOP relay to re-energize.

When the receiver unit fails to receive a beacon signal from a logged in transmitter for 2 seconds the STOP and LOGIN relays will drop out. To re-activate the receiver relays, the transmitter must be powered OFF to reset. Once reset, powering ON the transmitter within range of the receiver will cause the corresponding STOP and LOGIN relays to re-energize.

NOTE: If the transmitter moves out of range, causing the receiver unit to lose the beacon signal, the transmitter will blink "Out of Range" continually. Pressing the Power/Select button on the transmitter will clear this message and the transmitter will be ready to log in again.

To stop monitoring with their transmitter, while in range of the receiver, power the transmitter OFF. This will de-energize the LOGIN relay only, allowing the system to continue to operate without remote stop protection.

FAILSAFE RELAYS		
TRANSMITTER UNIT #	STOP	LOGIN
1	Relays 1 & 2	Relay 3
2	Relay 1 & 2	Relay 4

Failsafe Relays:

All relays are OFF at power up. When a transmitter logs in, both STOP relays will energize and the corresponding LOGIN relay will energize. If the second transmitter logs in while the first transmitter is already logged in, only its corresponding LOGIN relay will energize (the STOP relays are not affected). When either transmitter activates a STOP command, both STOP relays will immediately de-energize in the receiver.

After the STOP button is released, all logged in transmitters must be powered OFF to reset. Once reset, turn all transmitters back ON to log in again.

465P-8D-ESTOP-AC

OPTIONS, PAN ID & FREQUENCY SETUP

The unit is shipped from the factory with SEL1 switches in the open positions. Relay response is set to Failsafe, the unit can be reset from the transmitter, Pan ID is set to 1, and the unit is receiving commands on frequency 1. To change default settings, follow the instructions below:

1. ***IMPORTANT***
Disconnect power from unit.
2. Remove top cover.
3. Select desired options using the table.
4. Reattach cover.
5. Reconnect power to unit.
6. Programming is complete.

RELAY RESPONSE TO E-STOP EVENT			
SEL1 SW#	OPEN (default)	CLOSED	
SW1	Failsafe	Split	
SYSTEM RESET OPTIONS			
SEL1 SW#	OPEN (default)	CLOSED	
SW2	Relays can be reset from Transmitter	Power must be cycled to receiver following any E-stop or signal loss event	
PAN ID			
PAN ID	SW4	SW5	SW6
BWI	OPEN	OPEN	OPEN
BWI1	CLOSED	OPEN	OPEN
BWI2	OPEN	CLOSED	OPEN
BWI3	CLOSED	CLOSED	OPEN
BWI4	OPEN	OPEN	CLOSED
BWI5	CLOSE	OPEN	CLOSED
FREQUENCY SETUP			
NETWORK FREQUENCY	SW7	SW8	SW9
1 (default)	OPEN	OPEN	OPEN
2	CLOSED	OPEN	OPEN
3	OPEN	CLOSED	OPEN
4	CLOSED	CLOSED	OPEN
5	OPEN	OPEN	CLOSED
6	CLOSED	OPEN	CLOSED
7	OPEN	CLOSED	CLOSED
8	CLOSED	CLOSED	CLOSED
NOTE: SW3 not used on this model			
NOTE: The PAN ID identifier (BWI) will on systems that have been uniquely coded. The numbering will remain as shown here.			

465P-8D-ESTOP-AC

CONTROLS & INDICATORS

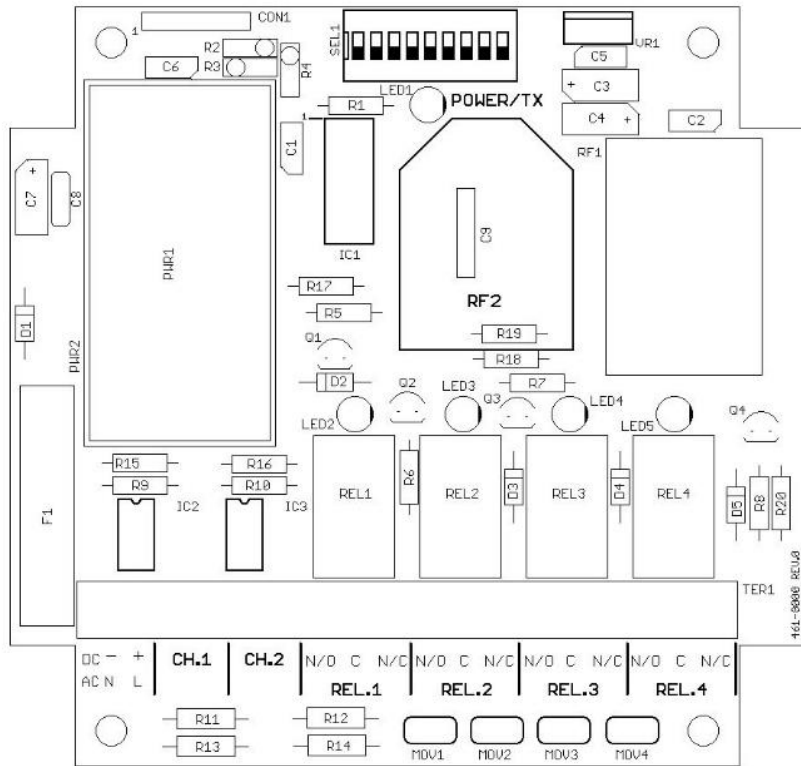

POWER/TX LED1	Dual color LED illuminates red while unit is booting up, changes to green when boot-up is successful and unit is ready to operate. If this LED fails to turn green, power unit off for 15-20 seconds, then reapply power.
LED2	Illuminates green while relay 1 is energized
LED3	Illuminates green while relay 2 is energized
LED4	Illuminates green while relay 3 is energized
LED5	Illuminates green while relay 4 is energized
REL1 – REL4	Four SPDT output control relays
RF1	RF Module that transmits/receives data

465P-8D-ESTOP-AC

SPECIFICATIONS

Power Supply	100-250 VAC, 5 W, 50/60 Hz
Relay Contacts	SPDT 5 amp @ 120VAC or 30VDC per channel
Fuse Protected	2 amp
Receiver Frequency	900 MHz Spread Spectrum
Receiver Range	Up to 5000 feet *
RF Networks	Eight Independent Network Frequencies
Operating Temperature	-40° F to +185° F
Enclosure	Polycarbonate, IP66 (NEMA 4)
<p>*Note: Max range statements are estimates based on a clear line of sight with few interferences. Actual range will vary based on transmitting power, orientation of transmitter and receiver, height of transmitting and receiving antennas, weather conditions, electronic interference, terrain, and physical obstacles, including but not limited to; walls, building structures, trees (foliage), metal objects, and landscape (hills, mountains).</p>	

ACCESSORIES

STANDARD ANTENNA (INCLUDED)	
900MHz TNC Portable "Rubber Duck" Antenna	49-1103
MOBILE/BASE ANTENNAS (OPTIONAL) Used to help achieve max range in non-line-of-sight and line-of-sight applications. Contact BWI Eagle for recommendations.	
900MHz Thru-Hole/Bracket Mount Mobile Antenna	49-2101
900MHz Magnet Mount Mobile Antenna	49-2102
900MHz Omni Directional Base Antenna	49-3101
900MHz Yagi Directional Base Antenna	49-3102
HIGH QUALITY COAX CABLE Used to connect external antennas to control unit.	
Flex Coax Cable w/Connectors (Available in 5', 15', 25', 30', 40', 60', 80', and 100' lengths)	49-4000-XX (XX = length in feet)
BULKHEAD EXTENSION Used to provide an external antenna connection when mounting control unit inside another enclosure.	
TNC Male to TNC Bulkhead Cable Assembly (Available in 2', 4', and 7' lengths)	49-5004-X-ISO (X = length in feet)

465P-8D-ESTOP-AC

DIMENSIONS

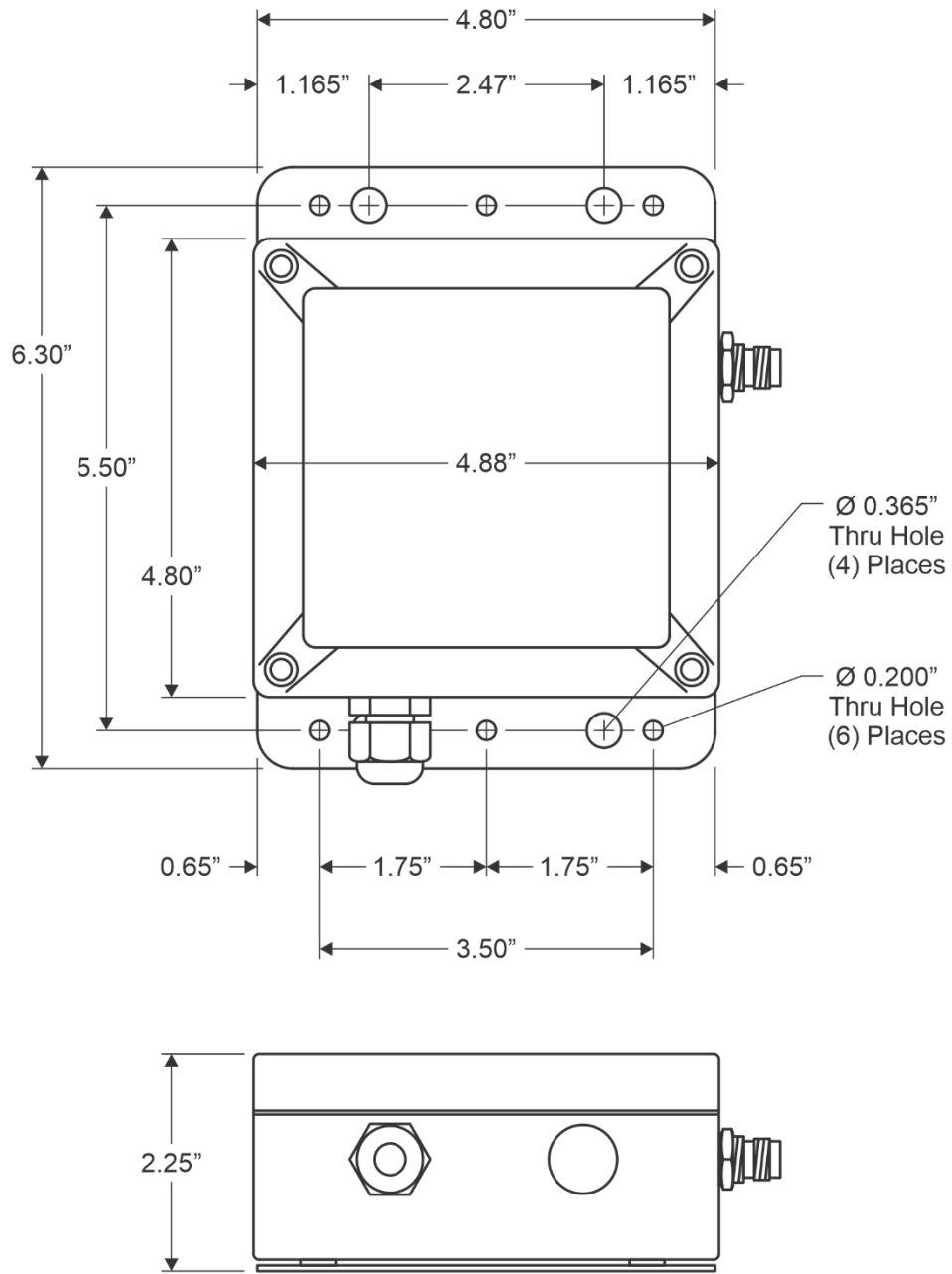



105 Bonnie Drive
Butler, PA 16002
724-283-4681
724-283-5939 (fax)
www.bwieagle.com

RELAY OUTPUT WIRING 4-Relay E-Stop Receiver

Receiver outputs are dry relay contacts, like an SPDT switch. When the relay is in a de-energized state, the N/C (normally closed) contact is connected to C (common). When the relay is energized the N/O (normally open) contact is connected to C (common).

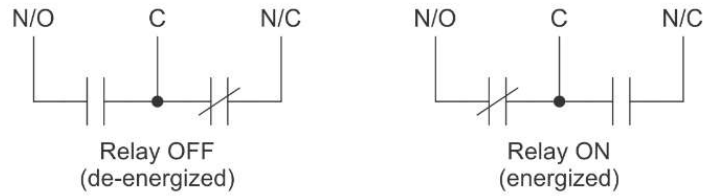

E-Stop Wiring Suggestion

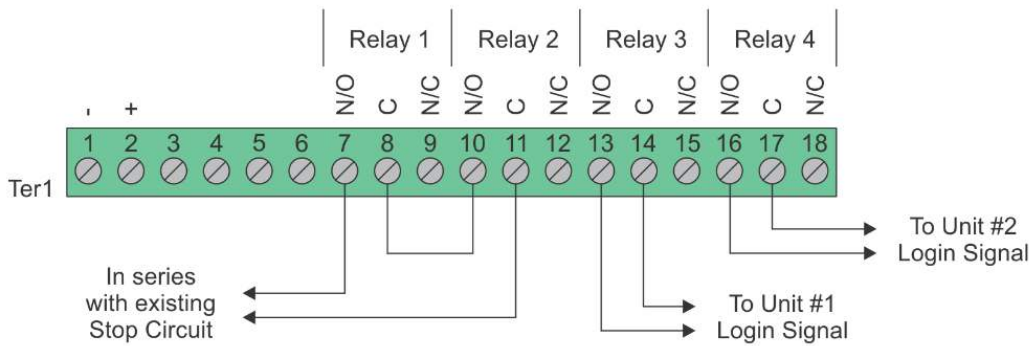

Normally Open Application with Externally Supplied Voltage

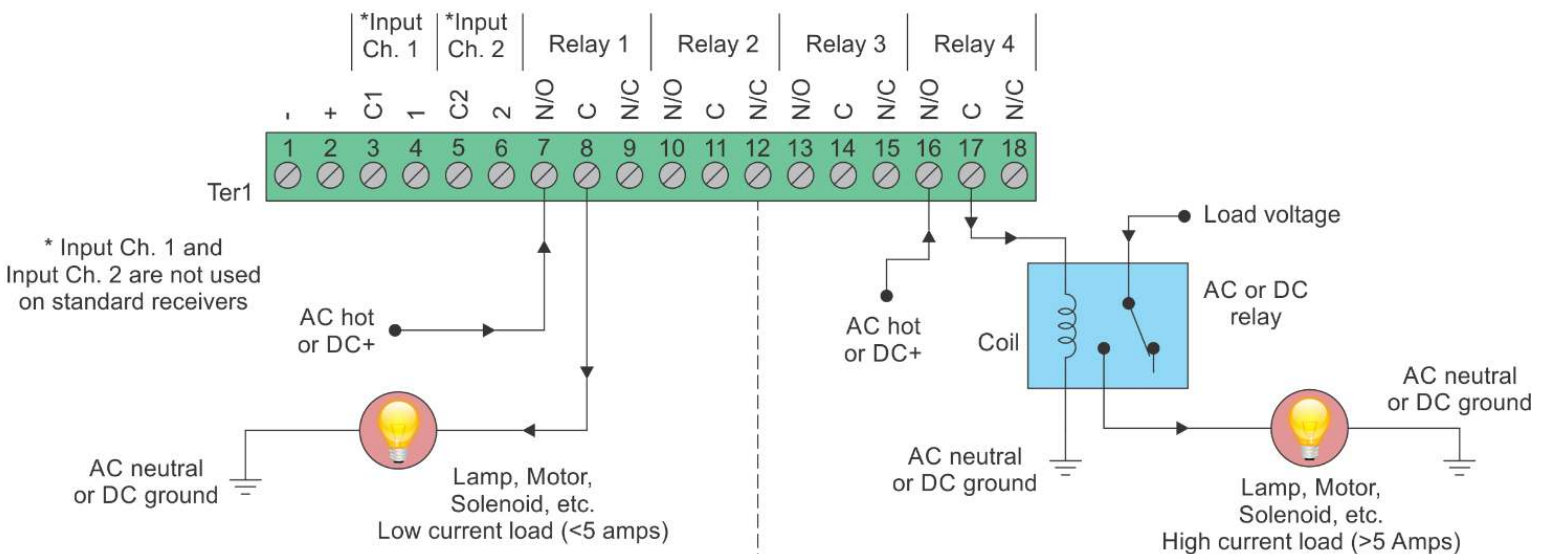

Internal Relay - Loads Less Than 5 Amps

Loads up to 5 Amps may be wired directly to the internal relays. Wiring to the N/O contact will cause the load to turn on when the relay is energized (the load is on when the relay is on). Wiring to the N/C contact will cause the load to turn on when the relay is de-energized (the load is on when the relay is off). AC or DC voltages can be switched through the relay.

External Relay - Loads Over 5 Amps

Loads over 5 Amps must use an external high current relay. Diagram shows how to turn on the relay using the lower current internal relay of the receiver. AC or DC voltages can be switched through the relay. Note: A protection diode for DC coils or an MOV for AC coils is recommended to reduce inductive EMI noise.

Wiring configurations shown here are examples. The wiring for your application may differ.
Call BWI Eagle for assistance or consult an electrician.